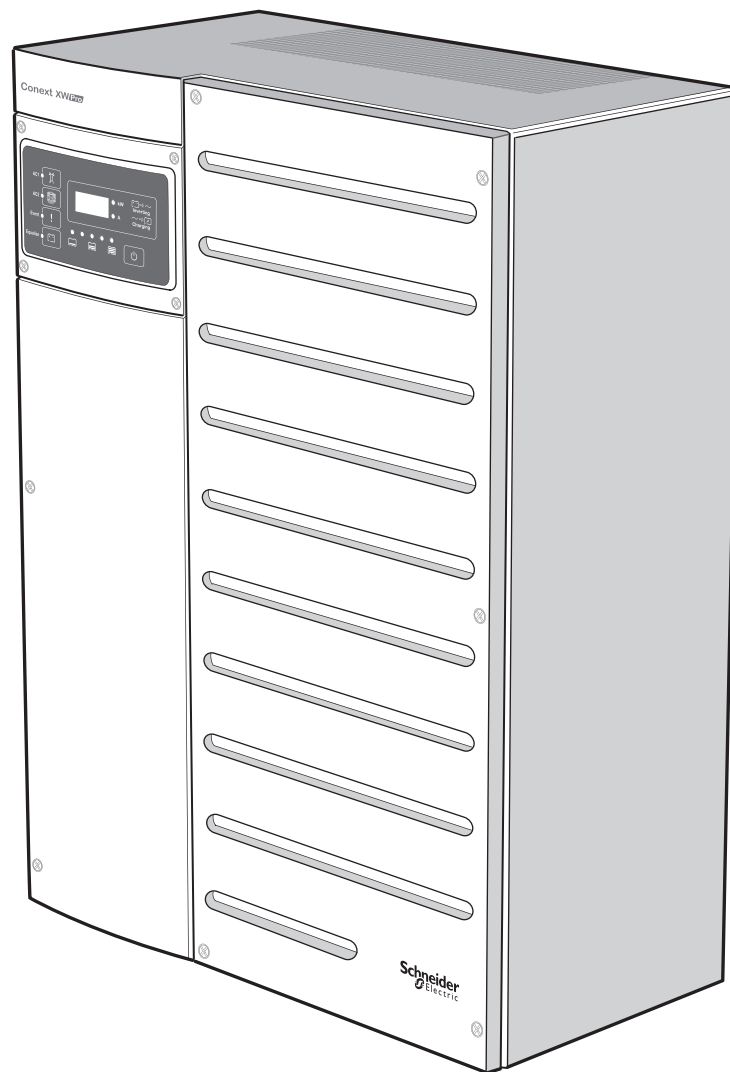


# Conext™ XWPro

## Installation Guide

975-0800-01-01 Revision A

August 2018



Copyright © 2018 Schneider Electric. All Rights Reserved.

Trademarks are owned by Schneider Electric Industries SAS or its affiliated companies. Other trademarks are owned by their respective companies.

### **Exclusion for Documentation**

UNLESS SPECIFICALLY AGREED TO IN WRITING, SELLER

(A) MAKES NO WARRANTY AS TO THE ACCURACY, SUFFICIENCY OR SUITABILITY OF ANY TECHNICAL OR OTHER INFORMATION PROVIDED IN ITS MANUALS OR OTHER DOCUMENTATION;

(B) ASSUMES NO RESPONSIBILITY OR LIABILITY FOR LOSSES, DAMAGES, COSTS OR EXPENSES, WHETHER SPECIAL, DIRECT, INDIRECT, CONSEQUENTIAL OR INCIDENTAL, WHICH MIGHT ARISE OUT OF THE USE OF SUCH INFORMATION. THE USE OF ANY SUCH INFORMATION WILL BE ENTIRELY AT THE USER'S RISK; AND

(C) REMINDS YOU THAT IF THIS MANUAL IS IN ANY LANGUAGE OTHER THAN ENGLISH, ALTHOUGH STEPS HAVE BEEN TAKEN TO MAINTAIN THE ACCURACY OF THE TRANSLATION, THE ACCURACY CANNOT BE GUARANTEED. APPROVED CONTENT IS CONTAINED WITH THE ENGLISH LANGUAGE VERSION WHICH IS POSTED AT <https://solar.schneider-electric.com>.

**Document Number:** 975-0800-01-01

Revision A

**Date:** August 2018

**Product Part Number:**

XW Pro 6848 NA

865-6848-21

### **Contact Information**

For country-specific details, please contact your local Schneider Electric Sales Representative or visit the Schneider Electric Solar Business website at: <https://solar.schneider-electric.com>

# READ AND SAVE THESE INSTRUCTIONS

## Safety Information

### Important Information

Read these instructions carefully and look at the equipment to become familiar with the device before trying to install, operate, service or maintain it. The following special messages may appear throughout this documentation or on the equipment to warn of potential hazards or to call attention to information that clarifies or simplifies a procedure.



The addition of either symbol to a “Danger” or “Warning” safety label indicates that an electrical hazard exists which will result in personal injury if the instructions are not followed.



This is the safety alert symbol. It is used to alert you to potential personal injury hazards. Obey all safety messages that follow this symbol to avoid possible injury or death.

### **DANGER**

**DANGER** indicates a hazardous situation which, if not avoided, **will result in** death or serious injury.

### **WARNING**

**WARNING** indicates a hazardous situation which, if not avoided, **could result in** death or serious injury.

### **CAUTION**

**CAUTION** indicates a hazardous situation which, if not avoided, **could result in** minor or moderate injury.

### **NOTICE**

**NOTICE** is used to address practices not related to physical injury.

### Please Note

Electrical equipment should be installed, operated, serviced, and maintained only by qualified personnel. No responsibility is assumed by Schneider Electric for any consequences arising out of the use of this material.

A qualified person is one who has skills and knowledge related to the construction, installation, and operation of electrical equipment and has received safety training to recognize and avoid the hazards involved. For more information, see Audience.

# Label Symbols

**NOTE:** The term "ground" is equivalent to "earth", and the use of these terms depends on local codes and standards. This document uses the term "ground" throughout.

The following symbols appear on labels on or in the inverter.



Hazardous voltage



Hot surface



5 mins

Stored energy hazard discharge time



Refer to the Installation or Operation instructions



Protective (grounding) conductor terminal



Direct current



Alternating current

# Product Labels

The Conext XW Pro inverter has different product labels designed to provide information on product ratings and specifications, provide safety information, and identify parts and functions of the inverter.

*Table 1 Product labels*

1	Main product ratings label
2	Front panel label
3	Main product safety label

# Main Product Ratings Label

The main product ratings label contains the inverter's product ratings and technical specifications. **Do not remove, cover, deface, or alter the main product label.** A localized main product label is available to install on the product.

Figure 1 Main product ratings label example

**Schneider Electric**  
**Conext™ XW20 6848 NA**  
 Inverter/Charger

**1** ———

**2** ———

**3** ———

**4** ———

**5** ———

**6** ———

**7** ———

**8** ———

**9** ———

<b>Charger Mode (25°C)</b>		120/240V	120V ~
Nominal Input Voltage	120/240V		120V ~
Max. Input Current	48A		48A ~
Input Power Factor	>0,98		>0,98 ~
Input Frequency Range	52-68Hz		52-68Hz ~
Output Voltage Range	40-64V		40-64V ~
Nominal Output Voltage	48.0V		48.0V ~
Max. Output Current	140A		120A ~
<b>Inverter Mode (25°C)</b>			
Nominal Output Voltage	120/240V		120V ~
Nominal Output Frequency	60Hz		60Hz ~
Max. Continuous Output Current	28A		48A ~
Max. Continuous Output Power	6,8kVA		5,76kVA ~
Input Voltage Range	42-60V		42-60V ~
Max. Input Current	180A		180A ~
<b>Grid Interactive Mode (40°C)</b>			
Nominal Grid Voltage	120/240V		120V ~
Grid Voltage Range	211-264V		105,6-132V ~
Nominal Frequency	60Hz		60Hz ~
Output Power Factor	>0,98		>0,98 ~
Max. Continuous Output Current	27A		48A ~
Max. Continuous Output Power	6,0kVA		5,76kVA ~
Input Voltage Range	47-58V		47-58V ~
Max. Continuous Input Current	160A		160A ~

Certified for use with 75°C copper conductors

Operating Temperature Range -25°C to +70°C  
 Part Number 865-6848-21

Serial number

Date of Manufacture

This Class B device complies with Part 15 of the FCC Rules and all requirements of the Canadian interference causing equipment regulations. Operation is subject to the following two conditions:  
 1. This device may not cause harmful interference.  
 2. This device must accept any interference received, including interference that may cause undesired operation

Factory Configuration 120/240V, 3 Wire   
 Optional Configuration 120V, 2 Wire

**UL 1741**  
**CSA 1021**  
**MC 15949**  
 LISTED

**IP20**  
 Type 1, Indoor Use Only

All trademarks are owned by Schneider Electric Industries  
 SAS or its affiliated companies. **Designed in Canada**  
 Made in Philippines

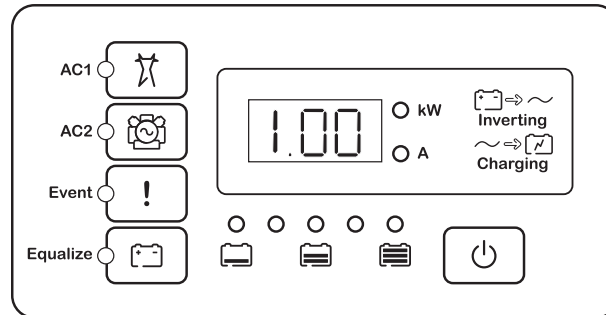
**NOTE:** This is for illustration purposes only. Actual ratings vary for each model.

1	Name of the product and model number
2	Charger ratings
3	Inverter ratings
4	Grid interactive ratings
5	Product part number and operating temperature range
6	Product serial number information
7	Product date of manufacture information
8	Regulatory markings
9	Enclosure rating

## Front Panel Label

The front panel label contains the LCD display and LED indicators. It also identifies the various buttons used in inverter operation. For information on the indicators and control button, see the *Figure 7 on page 1*.

*Figure 2 Inverter Information Panel*



## Main Product Safety Label

The main product safety label is the main safety label for the inverter which lists general hazards and instructions on avoiding them. The label is applied on the exterior of the inverter.

**Do not remove, cover, deface, or alter the main product safety label.** A localized label is available to install on the product.

For information on the symbols appearing in the label, see *Label Symbols on page 3*.

## Other Safety Labels

Other safety labels appear on many areas of the equipment to warn of potential hazards within those areas of the inverter or to call attention to information that clarifies or simplifies a procedure. Read and follow all safety labels before proceeding.

**Do not remove, cover, deface, or alter safety labels.** Localized safety labels are available to install on the product.

# Radio Frequency Interference Notices

## **Federal Communications Commission (FCC)**

This equipment has been tested and found to comply with the limits for a Class A digital device, pursuant to part 15 of the FCC Rules. These limits are designed to provide reasonable protection against harmful interference in a residential installation. This equipment generates, uses, and can radiate radio frequency energy and, if not installed and used in accordance with the instructions, may cause harmful interference to radio communications. However, there is no guarantee that interference will not occur in a particular installation. If this equipment does cause harmful interference to radio or television reception, which can be determined by turning the equipment off and on, the user is encouraged to try to correct the interference by one or more of the following measures:

- Reorient or relocate the receiving antenna.
- Increase the separation between the equipment and the receiver.
- Connect the equipment to a circuit different from that to which the receiver is connected.
- Consult the dealer or an experienced radio/TV technician for help.



# Audience

This guide is intended for any qualified personnel planning to install the Conext XW Pro inverter/charger and related system components. The qualified personnel have training, knowledge, and experience in:

- Installing electrical equipment.
- Applying all applicable installation codes.
- Analyzing and reducing the hazards involved in performing electrical work.
- Installing and configuring batteries.
- Selecting and using Personal Protective Equipment (PPE).

Servicing of batteries must only be performed or supervised by qualified personnel with knowledge of batteries and their required precautions. Keep unqualified personnel away from batteries.

No responsibility is assumed by Schneider Electric for any consequences arising out of the use of this material.

# About

## Purpose

This guide provides explanations and procedures for installing Schneider Electric Conext XW Pro inverter/charger.

- Operational instructions are available in the *Conext XW Pro Owner's Guide (document number 975-0801-01-01)*.
- Instructions for configuring inverter settings are also available in the *Conext XW Pro Owner's Guide (document number 975-0801-01-01)*.

For explanations and procedures related to other products, please contact the manufacturer of those products.

## Scope

The Installation Guide provides safety guidelines, detailed planning, and procedures for installing the Conext XW Pro inverter/charger and related system components. It does not provide details about configuration, operation, maintenance, or troubleshooting. See the Operation Guide or Owner's Guide of each device for this information. This Installation Guide does not provide details about particular brands of batteries, photoelectric cells, or generators. Consult individual battery manufacturers for this information.

## Abbreviations and Acronyms

CEC	California Energy Commission
CSA	Canadian Standards Association
GT	Grid Tie
LCD	Liquid Crystal Display
LED	Light Emitting Diode
MPPT	Maximum Power Point Tracking
NEC	US National Electrical Code NFPA-70
PV	Photovoltaic
PVGFP	PV Ground Fault Protection
UL	Underwriters Laboratories
VAC	Volts Alternating Current
VDC	Volts Direct Current

## Related Information

Find more information about Schneider Electric as well as its products and services at:  
[www.schneider-electric.com](http://www.schneider-electric.com).

For specific information on Solar, visit the Schneider Electric Solar Business website at:  
<https://solar.schneider-electric.com>.

For available accessories, see "*Optional Accessories*" on page 20.

# Product Safety Information

**IMPORTANT:** Remember to read and follow all product safety information in this document.

## General Safety Instructions

Before using the inverter/charger, read all instructions and cautionary markings on the unit, the batteries, and all appropriate sections of this manual.

- Use of accessories not recommended or sold by the manufacturer may result in a risk of fire, electric shock, or injury to persons.
- The inverter/charger is designed to be permanently connected to your AC and DC electrical systems. The manufacturer recommends that all wiring be done by a certified technician or electrician to ensure adherence to the local and national electrical codes applicable in your jurisdiction.
- To avoid a risk of fire and electric shock, make sure that existing wiring is in good condition and that wire is not undersized. Do not operate the inverter/charger with damaged or substandard wiring.
- Do not operate the inverter/charger if it has been damaged in any way.
- This unit does not have any user-serviceable parts. Do not disassemble the inverter/charger except where noted for connecting wiring and cabling. See your warranty for instructions on obtaining service. Attempting to service the unit yourself may result in a risk of electrical shock or fire. Internal capacitors remain charged after all power is disconnected.
- To reduce the risk of electrical shock, disconnect both AC and DC power from the inverter/charger before attempting any maintenance or cleaning or working on any components connected to the inverter/charger. Putting the unit in Standby mode will not reduce this risk.
- The inverter/charger must be provided with an equipment-grounding conductor connected to the AC input ground.
- Do not expose this unit to rain, snow, or liquids of any type. This product is designed for indoor use only. Damp environments will significantly shorten the life of this product and corrosion caused by dampness will not be covered by the product warranty.
- To reduce the chance of short-circuits, always use insulated tools when installing or working with this equipment.
- Remove personal metal items such as rings, bracelets, necklaces, and watches when working with electrical equipment.

**⚡ ⚠ DANGER****HAZARD OF ELECTRIC SHOCK, EXPLOSION, ARC FLASH, AND FIRE**

- Apply appropriate personal protective equipment (PPE) and follow safe electrical work practices. See NFPA 70E or CSA Z462.
- This equipment must only be installed and serviced by qualified electrical personnel.
- Never operate energized with covers removed
- Energized from multiple sources. Before removing covers identify all sources, de-energize, lock-out, and tag-out and wait 2 minutes for circuits to discharge
- Always use a properly rated voltage sensing device to confirm all circuits are de-energized.

**Failure to follow these instructions will result in death or serious injury.**

**⚡ ⚠ DANGER****HAZARD OF ELECTRIC SHOCK, EXPLOSION, ARC FLASH, AND FIRE**

- Disconnect negative and positive PV conductors before servicing. PV conductors are to be treated as Hazardous Live and must be disconnected.
- Normally GROUNDED conductors may be UNGROUNDED and ENERGIZED when a GROUND FAULT is indicated on the front panel. Must be serviced by qualified personnel.

**Failure to follow these instructions will result in death or serious injury.**

## Precautions when Working with Batteries

**NOTE:** Battery work and maintenance must be done by qualified personnel knowledgeable about batteries to ensure compliance with battery handling and maintenance safety precautions.

**⚠ DANGER****HAZARD OF ELECTRIC SHOCK, EXPLOSION, OR ARC FLASH**

- Remove watches, rings, or other metal objects.
- This equipment must only be installed and serviced by qualified electrical personnel.
- Keep sparks and flames away from the batteries.
- Use tools with insulated handles.
- Wear protective glasses, gloves and boots.
- Do not lay tools or other metal parts on top of batteries.

**Failure to follow these instructions will result in death or serious injury.**

**⚠ DANGER**

**STATEMENT OF HAZARD**

- Battery Circuit Breakers must be installed according to the specifications and requirements defined by Schneider Electric.s.
- Servicing of batteries must only be performed by qualified personnel knowledgeable about batteries and the required precautions. Keep unqualified personnel away from batteries.
- Disconnect the charging source prior to connecting or disconnecting battery terminals.

**Failure to follow these instructions will result in death or serious injury.**

**Limitations on Use**

**⚠ WARNING**

**HAZARD DUE TO UNINTENDED USE**

The Conext XW Pro inverter is not intended for use in connection with life support systems or other medical equipment or devices. The Conext XW Pro inverter can only be used in grid-interconnected, off grid, and integrated PV systems. It is not suitable for any other application areas.

**Failure to follow these instructions can result in death, serious injury, or equipment damage.**

**Explosive Gas Precautions**

**⚠ WARNING**

**EXPLOSION HAZARD**

The Conext XW Pro is not ignition protected. To prevent fire or explosion, do not install this product in locations that require ignition-protected equipment. This includes any space containing gasoline-powered machinery, fuel tanks, as well as joints, fittings, or other connections between components of the fuel system.

**Failure to follow these instructions can result in death, serious injury, or equipment damage.**

Working in the vicinity of lead acid batteries is dangerous. Batteries generate explosive gases during normal operation. Therefore, you must read this Installation Guide and follow the instructions exactly before installing or using your inverter/charger.

To reduce the risk of battery explosion, follow these instructions and those published by the battery manufacturer and the manufacturer of the equipment in which the battery is installed.

# Contents

Safety Information .....	2
Label Symbols .....	3
Product Labels .....	4
Radio Frequency Interference Notices .....	7
Audience .....	8
About .....	9
Purpose .....	9
Scope .....	9
Abbreviations and Acronyms .....	9
Related Information .....	10
Product Safety Information .....	11
General Safety Instructions .....	11
Precautions when Working with Batteries .....	12
Limitations on Use .....	13
Explosive Gas Precautions .....	13
Introduction .....	18
Overview .....	19
Inside the Box .....	19
Conext XW Pro and System Components .....	19
Battery Temperature Sensor .....	19
Conext XW Jumpers (For Single-Phase Conversion) .....	20
Conext XW Pro Features .....	20
Optional Accessories .....	20
Conduit Box .....	21
Power Distribution Panel (PDP) .....	21
PDP 120/240V 60A Breaker Kit .....	22
Conext MPPT 60 150 Solar Charge Controller .....	23
Conext MPPT 80 600 Solar Charge Controller .....	23
Conext SCP .....	24
Conext AGS .....	24
Conext Gateway .....	24
Conext Battery Monitor .....	25
100A, 125VDC Breaker Master Pack (12 units) .....	25
80A, 125VDC Breaker Master Pack (12 units) .....	25
60A, 160VDC Breaker Master Pack (48 units) .....	25
250A, 160VDC Breaker Master Pack (6 units) .....	25
Pre-Installation Planning .....	26

Pre-Installation .....	27
Planning the Installation .....	27
Installation Tools and Materials .....	27
Location .....	27
Clearance Requirements .....	28
Knockout Selection .....	29
Air Filter and AUX Port Connector Installation .....	30
Wall-Mounting .....	31
Installing the Mounting Plate .....	32
Wall-Mounting the Conext XW Pro and PDP .....	33
Installing the Conext XW Pro Conduit Box .....	34
Communications Network Preparation .....	36
Battery Bank Preparation .....	37
Battery Bank Requirements .....	38
Battery Cable Requirements .....	38
Torque Values .....	40
Torque values for the Conext XW Pro .....	40
Torque Values for the Power Distribution Panel (PDP) .....	40
Wiring .....	42
Removing the AC Access Panel and PDP Internal Faceplates .....	43
AC Access Panel Removal .....	43
Conext XW Pro Power Distribution Panel Internal Faceplate Removal .....	44
Communication Ports and BTS Port .....	46
AUX Port .....	46
Wiring the Conext XW Pro with a PDP .....	49
Conext XW Pro Inverter/Charger Grounding .....	49
Grounding the DC System .....	49
Battery Temperature Sensor Installation .....	51
Making DC Connections .....	52
Making AC Connections .....	56
AC System Bonding .....	59
Basic Functional Test – Single Inverter .....	67
Confirming All Connections .....	67
Applying DC Power to the Inverter .....	68
Enabling the Inverter .....	68
AC Voltage Check .....	71
Confirming Battery Charger Operation .....	71
Conext XW Pro Inverter/Charger Grounding .....	73



Wiring the Conext XW Pro Inverter/Charger without a PDP .....	73
Pre-Installation Steps .....	74
Feed-in Protection Requirements .....	75
Conext XW Pro Inverter/Charger Grounding .....	75
Grounding the DC System .....	76
<b>Communication .....</b>	<b>82</b>
The Xanbus Network .....	83
Network Components .....	83
Installing the Network .....	86
Before You Begin the Installation .....	86
Installation Tools and Materials .....	86
Installing Xanbus cables .....	86
Guidelines for Routing the Xanbus Cables .....	88
<b>Access Installation .....</b>	<b>90</b>
Conext SCP Installation .....	91
Installing the SCP via the Xanbus Network .....	91
Replacing the Inverter Information Panel with the SCP .....	92
Verifying the Installation .....	95
<b>Specifications .....</b>	<b>96</b>
Specifications .....	97
Electrical Specifications .....	97
Conext XW Pro Overload Capability .....	98
Output Power Versus Ambient Temperature .....	99
Conext XW Pro Efficiency .....	100
Mechanical Specifications .....	102
Accessories .....	103
<b>Wiring Diagrams .....</b>	<b>104</b>
Single-Inverter System (Backup Only) Without a Power Distribution Panel (PDP) ..	105
Single-Inverter System (Backup Only) With a Power Distribution Panel (PDP) .....	106
Single-Inverter System Renewable Energy (Solar) .....	107
Dual-Inverter System Renewable Energy (Solar) .....	108



# 1 Introduction

## What's in This Chapter?

<b>Overview</b> .....	<b>19</b>
<b>Inside the Box</b> .....	<b>19</b>
Conext XW Pro and System Components .....	19
Battery Temperature Sensor .....	19
Conext XW Jumpers (For Single-Phase Conversion) .....	20
<b>Conext XW Pro Features</b> .....	<b>20</b>
<b>Optional Accessories</b> .....	<b>20</b>
Conduit Box .....	21
Power Distribution Panel (PDP) .....	21
PDP 120/240V 60A Breaker Kit .....	22
Conext MPPT 60 150 Solar Charge Controller .....	23
Conext MPPT 80 600 Solar Charge Controller .....	23
Conext SCP .....	24
Conext AGS .....	24
Conext Gateway .....	24
Conext Battery Monitor .....	25
100A, 125VDC Breaker Master Pack (12 units) .....	25
80A, 125VDC Breaker Master Pack (12 units) .....	25
60A, 160VDC Breaker Master Pack (48 units) .....	25
250A, 160VDC Breaker Master Pack (6 units) .....	25

## Overview

The Conext XW Pro is a modular building block sine-wave inverter/charger that can be used for residential and commercial battery based off-grid, grid backup, and grid interactive applications.

The Conext XW Pro is a self-contained DC to AC inverter, battery charger, and integrated AC transfer switch. It is configurable in a hybrid system to operate with generators and renewable energy sources. These configurations are capable of extending battery based off-grid/backup autonomy.

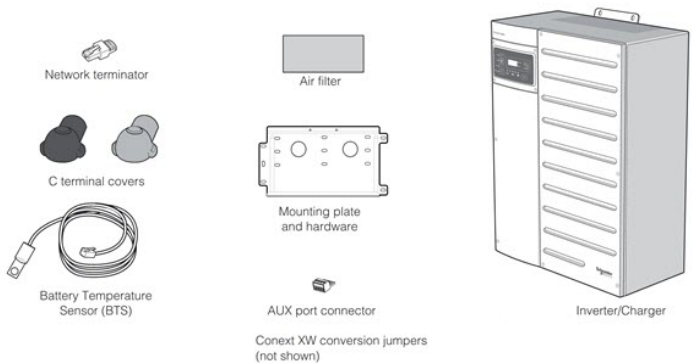
**Note:** The Conext XW Pro inverter/chargers are designed for operation with single phase, three wire (120 V/240 V) AC sources and should not be connected to a three-phase AC source.

## Inside the Box

### Conext XW Pro and System Components

The following system components are included in this package. If any items are missing, contact your authorized dealer.

Figure 3 System Components



### Battery Temperature Sensor

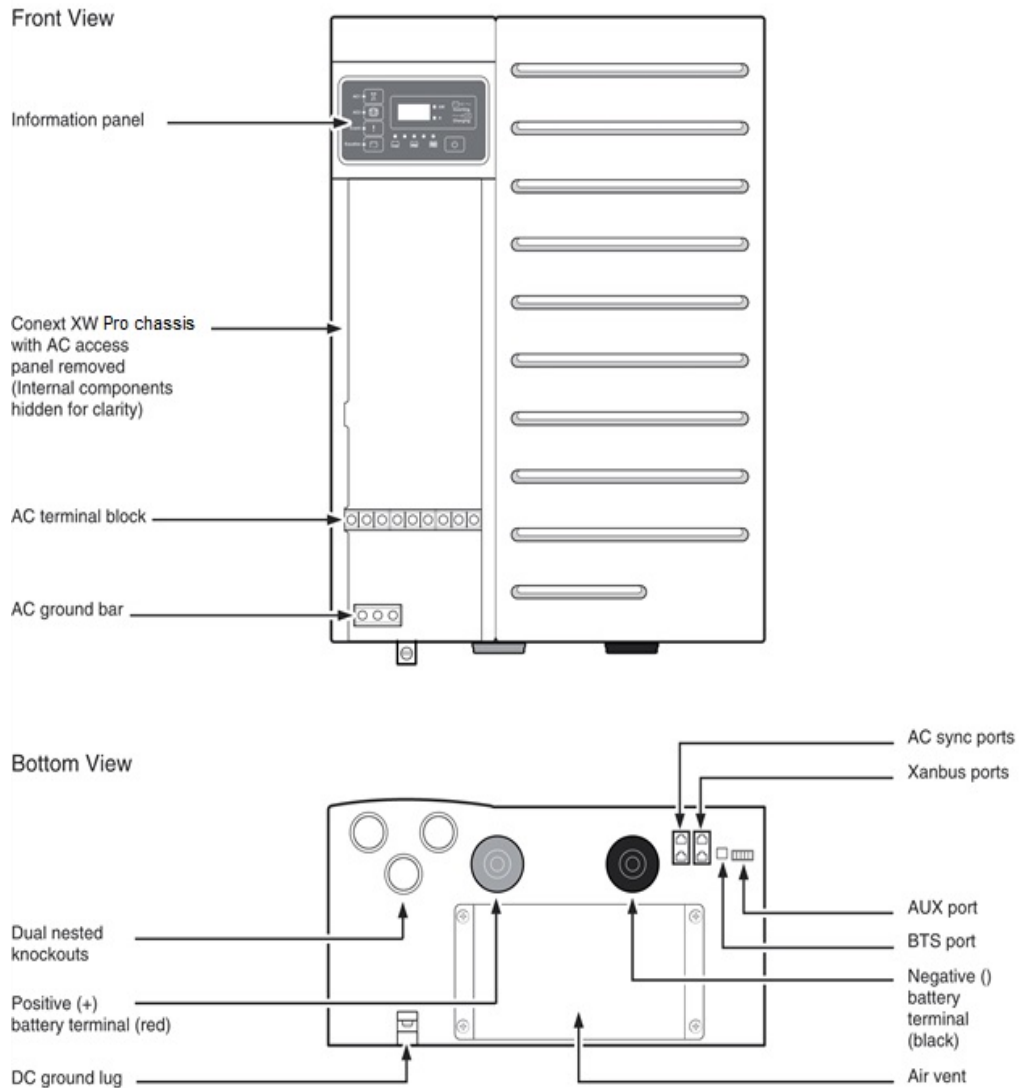
The Battery Temperature Sensor (BTS) included in this package monitors the temperature of the battery bank and adjusts the charging accordingly. For installation instructions, see *Removing the AC Access Panel and PDP Internal Faceplates* on page 43 of this Installation Guide.

## Conext XW Jumpers (For Single-Phase Conversion)

Conext XW Jumpers are used to reconfigure a standard unit 120V/240V, three-wire, split-phase model to accept a 120 V, 2-wire, single-phase connection. Use the jumpers to reconfigure the transformer wires. For more information, see *Converting 120 V/240 V Split-Phase to 120 V Single-Phase*.

## Conext XW Pro Features

Figure 4 Features



## Optional Accessories

The following optional accessories are available for the Conext XW Pro inverter/charger.

For an up-to-date list, call an authorized dealer or visit

<https://solar.schneider-electric.com>.

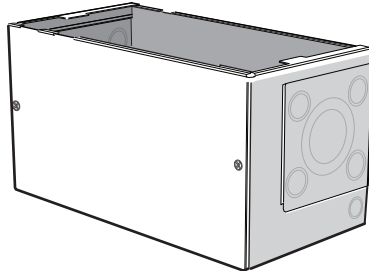
## Conduit Box

### Part Number 865-1025-01

The Conduit Box provides an enclosure over the bottom of the Conext XW Pro and covers the cabling that runs underneath.

For installation instructions, see *Installing the Conext XW Pro Conduit Box* on page 34.

Figure 5 Conduit Box



**Note:** Your installation may require the inclusion of the Conduit Box, depending on local electrical code. Consult your local electrical authority to ensure your installation is code-compliant.

## Power Distribution Panel (PDP)

### Part Number 865-1015-01

The Power Distribution Panel (PDP) is factory wired and labelled with everything to support a single-inverter installation.

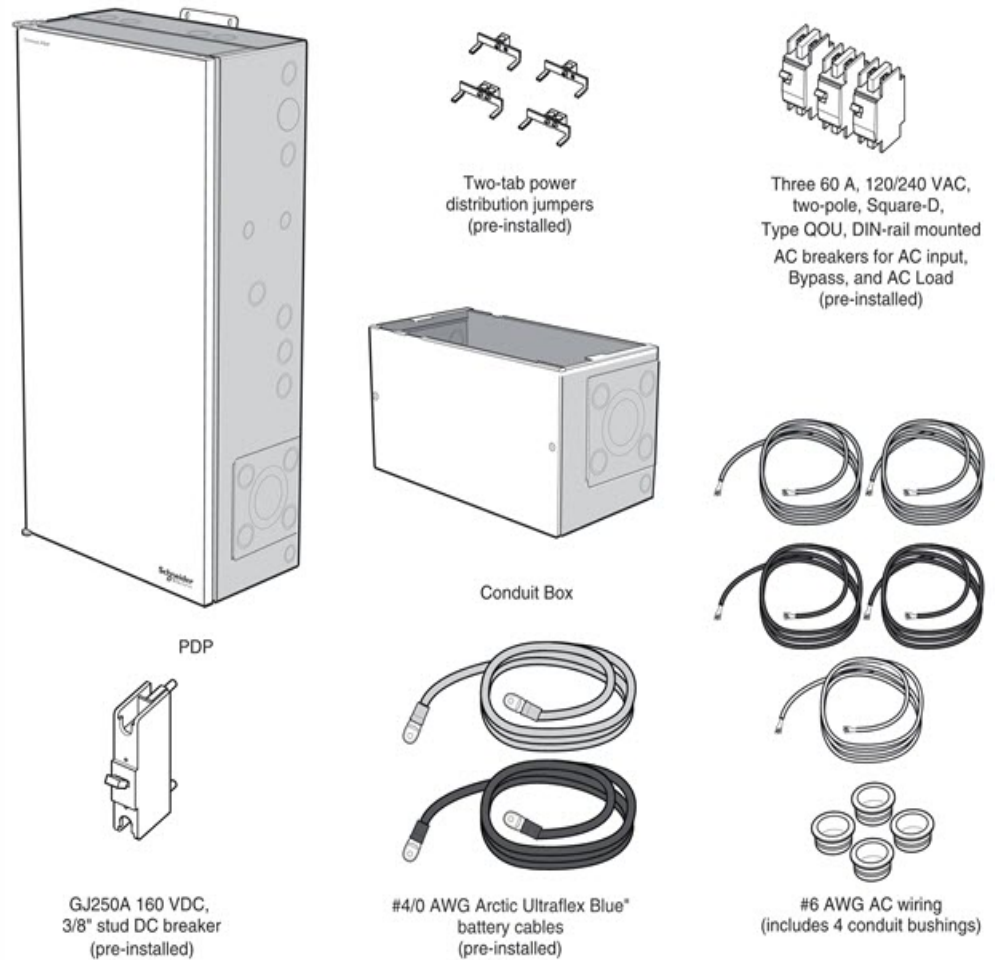
Internal wiring and breakers can be added to expand the Conext XW Pro with up to three inverters, four charge controllers, or other equipment to support 120/240 volt, three-wire, single-phase systems.

The PDP interfaces with the following Conext products:

- XW Pro 6848 NA inverter/charger
- Conext MPPT solar charge controllers (breakers and wiring not included)
- C-Series Charge Controllers (breakers and wiring not included).

The Conext XW Pro Power Distribution Panel includes the components shown below.

Figure 6 Conext XW Pro Power Distribution Panel with Conduit Box



Not shown:

- One ground terminal bus bar
- One neutral terminal bus bar
- One battery negative terminal bus bar
- Zap-strap cable ties (3x)

## PDP 120/240V 60A Breaker Kit

**Part Number 865-1215-01**

Included: Three 60 A, 120/240 VAC, two-pole, Square-D, type QOU, DIN-rail mountable AC breakers, jumpers, bypass interlock.

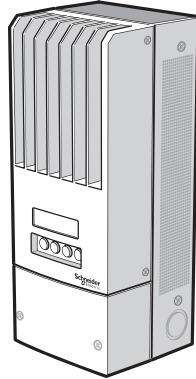
## Conext MPPT 60 150 Solar Charge Controller

### Part Number 865-1030-1

The Conext MPPT solar charge controller is a photovoltaic (PV) charge controller that tracks the maximum power point of a PV array to deliver the maximum available current for charging batteries.

For more information, go to <https://solar.schneider-electric.com>.

Figure 7 MPPT 60 150



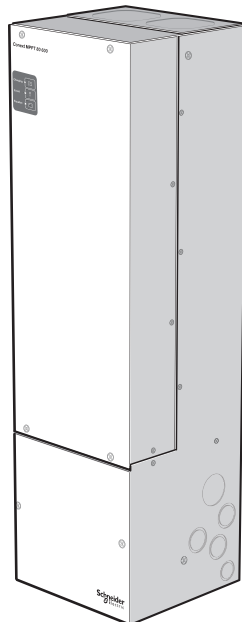
## Conext MPPT 80 600 Solar Charge Controller

### Part Number 865-1032

The Conext MPPT solar charge controller offers an industry-first set of integration features and top performance that allows for large PV array systems to be easily installed and connected to the battery bank at the lowest possible cost.

For more information, go to <http://solar.schneider-electric.com>.

Figure 8 MPPT 80 600





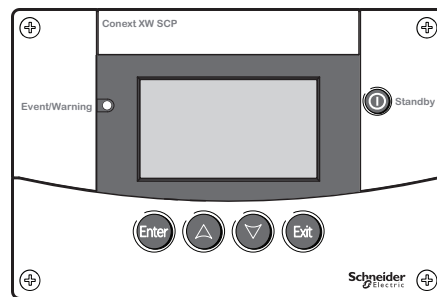
## Conext SCP

### Part Number 865-1050-01

The Conext System Control Panel (SCP) gives a single point of control to set up and monitor your entire Conext XW Pro installation.

Featuring a graphical, backlit liquid crystal display, the SCP displays configuration and diagnostic information for devices connected to the network.

Figure 9 Conext SCP



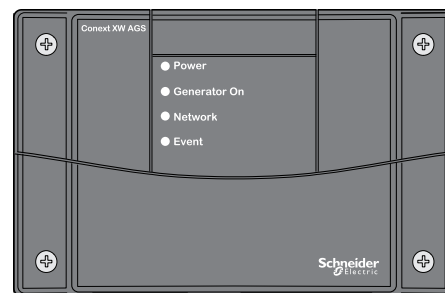
## Conext AGS

### Part Number 865-1060-01

The Conext AGS can automatically start and stop a generator, providing your Conext XW Pro Inverter/Charger with power to recharge depleted batteries while powering your loads. The AGS adds intelligence to power management and minimizes time spent monitoring batteries and inverter loads.

For more information, see the *Conext AGS Owner's Guide*.

Figure 10 Conext AGS



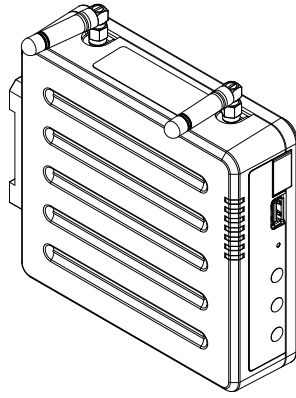
## Conext Gateway

### Part Number 865-0329

The Conext Gateway is a multi-function communication device that provides an overall view of system performance for residential power monitoring systems. It also provides a communications gateway between a network of Xanbus™-enabled devices and Modbus devices.

For more information, see the *Conext Gateway Owner's Guide*.

Figure 11 Conext Gateway



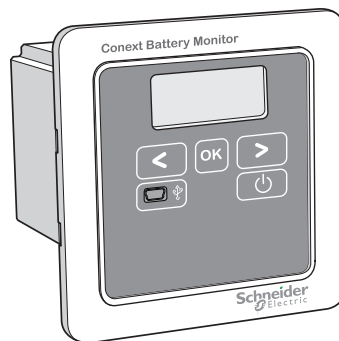
## Conext Battery Monitor

### Part Number 865-1080-01

The Battery Monitor is Xanbus-enabled, and features a local display to selectively show the estimated operating voltage, current, consumed amp-hours, remaining capacity and remaining hours in your 48 V battery bank.

For more information, see the *Conext Battery Monitor Quick Start Guide*.

Figure 12 Conext Battery Monitor



### 100A, 125VDC Breaker Master Pack (12 units)

Part Number 865-1080

### 80A, 125VDC Breaker Master Pack (12 units)

Part Number 865-1070

### 60A, 160VDC Breaker Master Pack (48 units)

Part Number 865-1075

### 250A, 160VDC Breaker Master Pack (6 units)

Part Number 865-1065

## 2 Pre-Installation Planning

### What's in This Chapter?

<b>Pre-Installation</b> .....	<b>27</b>
Planning the Installation .....	27
Installation Tools and Materials .....	27
Location .....	27
Clearance Requirements .....	28
Knockout Selection .....	29
Air Filter and AUX Port Connector Installation .....	30
<b>Wall-Mounting</b> .....	<b>31</b>
Installing the Mounting Plate .....	32
Wall-Mounting the Conext XW Pro and PDP .....	33
Installing the Conext XW Pro Conduit Box .....	34
<b>Communications Network Preparation</b> .....	<b>36</b>
<b>Battery Bank Preparation</b> .....	<b>37</b>
Battery Bank Requirements .....	38
Battery Cable Requirements .....	38
<b>Torque Values</b> .....	<b>40</b>
Torque values for the Conext XW Pro .....	40
Torque Values for the Power Distribution Panel (PDP) .....	40

## Pre-Installation

Before installing the Conext XW Pro, read all instructions and cautionary markings in this Installation Guide.

**Note:** Obtain all necessary permits prior to starting the installation. **Installations must meet all local codes and standards.** Installation of this equipment should only be performed by skilled personnel such as qualified electricians and Certified Renewable Energy (RE) System installers.

### **WARNING**

#### **HEAVY EQUIPMENT**

The Conext XW Pro weighs approximately 120 lbs. (54 kg). A two-person lift is required. To prevent personal injury, always use proper lifting techniques during installation.

**Failure to follow these instructions can result in death, serious injury, or equipment damage.**

## Planning the Installation

- Read this entire chapter before beginning the installation. It is important to plan the installation from beginning to end.
- Assemble all tools and materials needed for the installation.

## Installation Tools and Materials

To complete the installation, you will need the following tools:

- Socket wrench, appropriately sized
- Phillips head screwdriver, appropriately sized
- Level

Depending on your installation, additional hardware may be required. The following items are not included with the Conext XW Pro:

- Battery cables
- Grounding wire: #14 AWG to #2 AWG (1.63mm to 6.54mm)
- Lag bolts to secure the mounting plates
- Screws for mounting the Conduit Box
- Additional wiring to connect the PDP to the inverter load sub-panel and utility grid
- Appropriate materials and hardware for additional wall-mount support

## Location

The Conext XW Pro is certified for dry, indoor (heated or unheated) installations only.

Locate any electronic equipment susceptible to radio frequency and electromagnetic interference as far away from the inverter as possible.

## Fire safety

### **⚠ WARNING**

#### **IGNITION AND FIRE HAZARD**

This equipment is not ignition protected. To prevent fire or explosion, do not install this product in locations that require ignition-protected equipment. This includes any confined space containing lead acid batteries, or flammable chemicals such as, natural gas (NG), liquid petroleum gas (LPG) or gasoline (Benzine/Petrol).

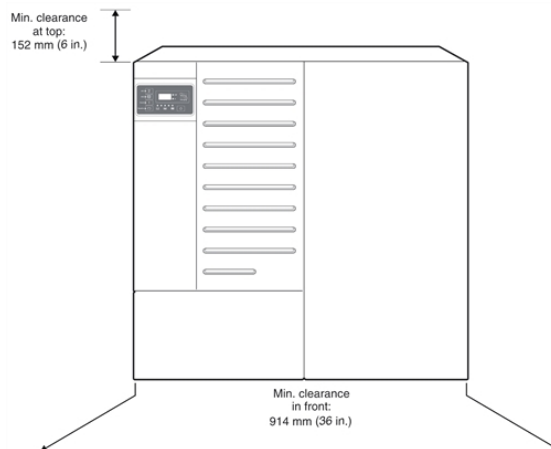
- Do not install in a confined space with machinery powered by flammable chemicals, or storage tanks, fittings, or other connections between components of fuel or flammable chemical systems.
- Do not install the inverter near readily flammable materials such as cloth, paper, straw, or plastic sheeting. Keep flammable materials a minimum distance of 600 cm (24 in.) from the top surface and 30 cm (12 in.) from either side surface and the front of the Conext XW Pro Inverter/Charger.

**Failure to follow these instructions can result in death, serious injury, or equipment damage.**

## Clearance Requirements

Provide at least 91 cm (36 in.) of clearance in front of the inverter, and a minimum of 15 cm (6 in.) of clearance at the top and bottom of the inverter for ventilation. Ensure the vents remain unobstructed, and that the Conext XW Pro Power Distribution Panel door has adequate room to fully open.

*Figure 13 Example of clearance requirements for a Conext XW Pro with PDP*



## Knockout Selection

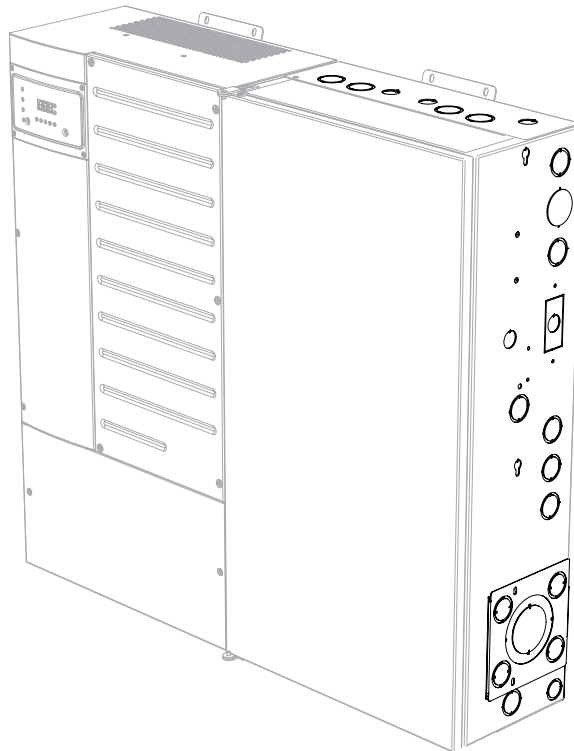
**Note:** Do not drill, cut, or punch holes into the Conext XW Pro, Conduit Box or Power Distribution Panel (PDP). Use only the knockouts provided for conduit entry.

The Conext XW Pro, Power Distribution Panel (PDP), and Conduit Box are equipped with nested dual knockouts for wiring through conduits.

Read "*Removing the AC Access Panel and PDP Internal Faceplates*" on page 43 and choose the knockouts for your installation.

See below, for an example of available knockouts along the top and side of the Power Distribution Panel (PDP).

*Figure 14 Example of available knockouts on the PDP*



Remove your choice of knockouts from the Conext XW Pro chassis, Conduit Box, and/or Power Distribution Panel (PDP). Ensure that no debris remains inside the chassis. Insert appropriately-sized conduit bushings into each conduit hole.

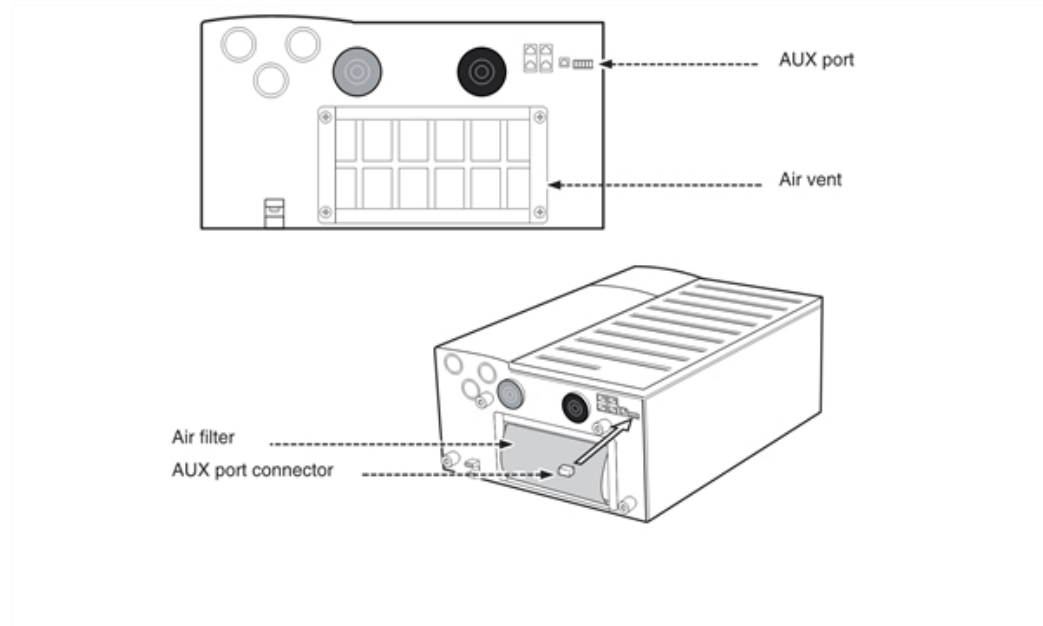
## Air Filter and AUX Port Connector Installation

Insert the air filter by tucking it into the grooves on the sides of the air vent cover (See *Figure 15*.)

If you are planning to use the auxiliary (AUX) port features, insert the AUX port connector into the AUX port. (See *Pre-Installation*.)

For more information, see *AUX Port* on page 46 of this Guide.

*Figure 15 Air Filter and AUX Port Connector Installation*



# Wall-Mounting

**⚠ WARNING**

**HEAVY EQUIPMENT**

The Conext XW Pro can cause serious injury if it falls or is dropped on a person.

For structural and seismic stability, the Conext XW Pro must be mounted onto a vertical supporting surface strong enough to support a minimum of 500 lbs. (227 kg).

**Failure to follow these instructions can result in death, serious injury, or equipment damage.**

A mounting plate is included with each Conext XW Pro and Power Distribution Panel (PDP), designed to meet standards for structural and seismic stability. When properly installed, the system also meets Section 59 of UL 1741 for Static Loads.

Each Conext XW Pro and Power Distribution Panel (PDP) requires a separate generic-Mounting Plate. Attach the mounting plate to the wall before you attach the Conext XW Pro or Power Distribution Panel (PDP) to the mounting plate.

Each Mounting Plate requires a minimum of four 1/4-inch diameter lag bolts or other fasteners (not included). The fasteners must be strong enough to support 500 lbs (227 kg).

The type of fastener required to secure the mounting plate varies according to the vertical surface and wall structure of your installation location. For a list of recommended fasteners, see *Pre-Installation*, below.

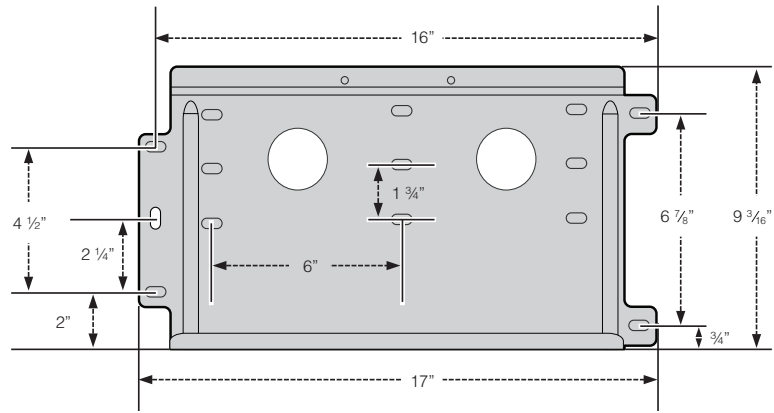
*Table 2 Recommended fasteners*

Structure	Required Fastener	Screws Per Plate
Wood studs at 16" on-center (O.C.)	1/4" Ø × 3 1/2" long lag screw	Four
Wood studs not at 16" O.C. (3/4" minimum plywood panel required)	1/4" Ø × 1" long wood screw	Six
Steel studs at 16" O.C. (minimum 18 gauge)	1/4" Ø self-drilling screw	Four

The holes of each Mounting Plate are spaced 16 inches (40 cm) apart, so that the mounting plate will span two wall studs spaced 16 inches on-center. Additional mounting holes are provided to allow for other mounting options.



Figure 16 Mounting plate dimensions



**Note:** If the wall does not have 16-inch (40 cm) on-center studs, you will need to provide adequate support for the Mounting Plates. For example, a sheet of plywood can be attached to the wall, and the Mounting Plates can then be attached to plywood.

## Installing the Mounting Plate

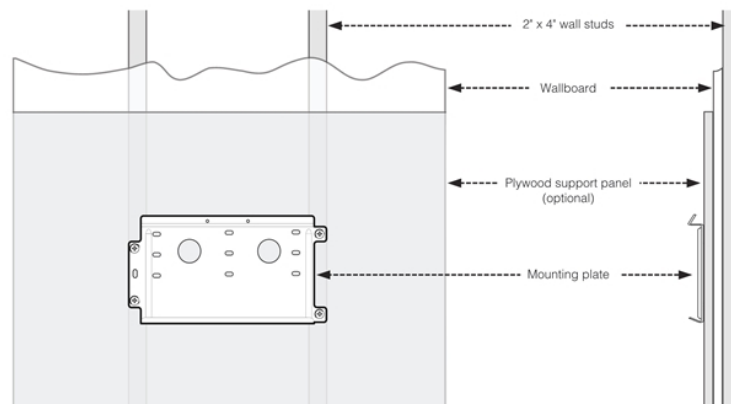
To install the mounting plate:

1. Locate the wall studs.
2. If necessary, secure a  $\frac{3}{4}$ " plywood panel or other appropriate additional support panel to the wall studs. The additional support panel must span at least three wall studs.

**Note:** To secure the additional support panel to the wall, use hardware sized to support a minimum of 500 lbs. (227 kg). (Hardware not included.)

3. Using a level, secure the first mounting bracket to the wall. Ensure the mounting plate is centered on the wall studs, as shown in *Pre-Installation*. Use recommended anchoring hardware to secure the plate (see *Pre-Installation*).

Figure 17 Mounting plate centered on wall studs



### Installation tip

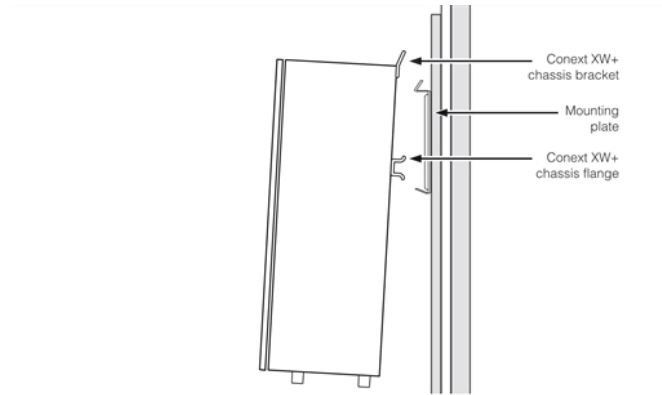
If you install the bottom of the mounting plate at 60" (152 cm) from floor, the inverter information panel will be approximately 65" from the floor.

## Wall-Mounting the Conext XW Pro and PDP

### To wall-mount the Conext XW Pro Inverter/Charger:

1. Align the flange on the back of the Conext XW Pro chassis with the bottom edge of the mounting plate, as shown in *Pre-Installation*.

Figure 18 Wall-mounting the Conext XW Pro



### **⚠ WARNING**

#### **HEAVY EQUIPMENT**

The Conext XW Pro weighs approximately 120 lbs. (54 kg). A two-person lift is required. To prevent personal injury, always use proper lifting techniques during installation.

**Failure to follow these instructions can result in death, serious injury, or equipment damage.**

2. Lower the Conext XW Pro chassis flange onto the mounting plate.
3. Secure the bracket at the top of the Conext XW Pro chassis with two #10 self-tapping screws (included).

#### **Installation tip**

The PDP is designed to mount on the right side of the inverter/charger, but it can be configured to mount on the left side instead. For more information, see the *Power Distribution Panel (PDP) Installation Guide*.

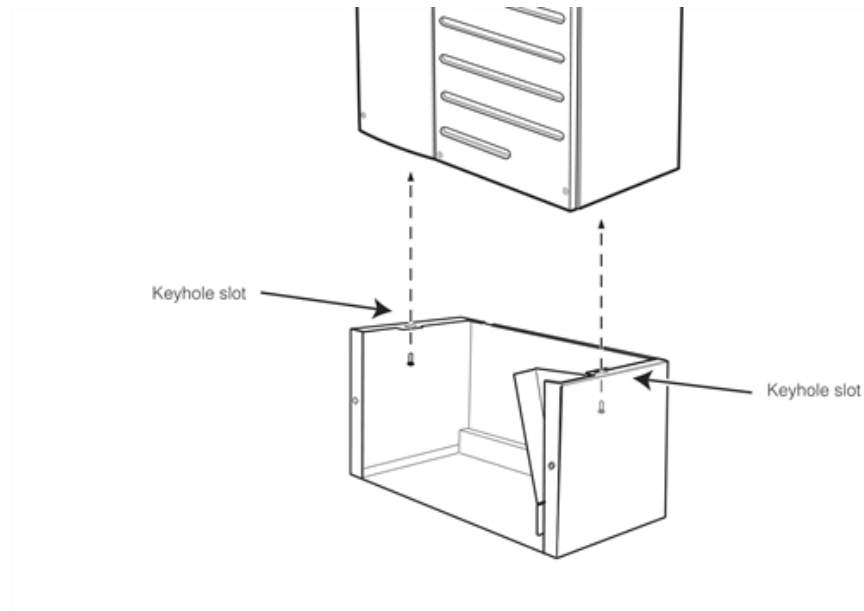
## Installing the Conext XW Pro Conduit Box

The Conduit Box is divided into two parts: the rear panel and the front panel.

To secure the Conduit Box to the Conext XW Pro chassis:

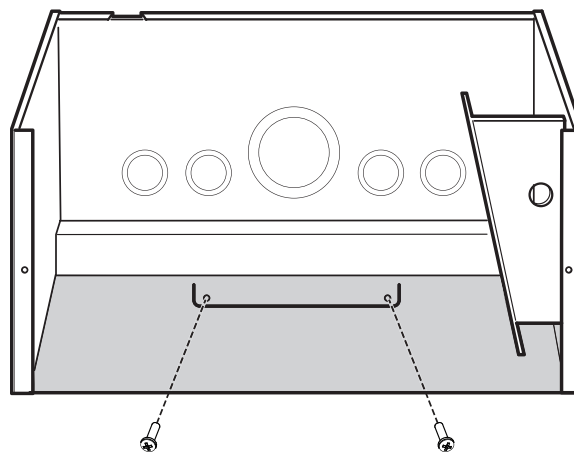
1. Remove both #10 screws from the bottom of the Conext XW Pro chassis.
2. Find the keyhole slots located under the top of the rear panel.
3. Align the keyhole slots on the top panel of the Conduit Box with the corresponding #10 screws on the bottom of the inverter.

Figure 19 Conduit Box keyhole alignment



4. Secure the Conduit Box to the inverter with the both #10 screws.
5. Using two screws (not included), secure the bracket at the bottom edge of the rear panel to the wall. See *Pre-Installation*.

Figure 20 Wall-mounting the Conduit Box

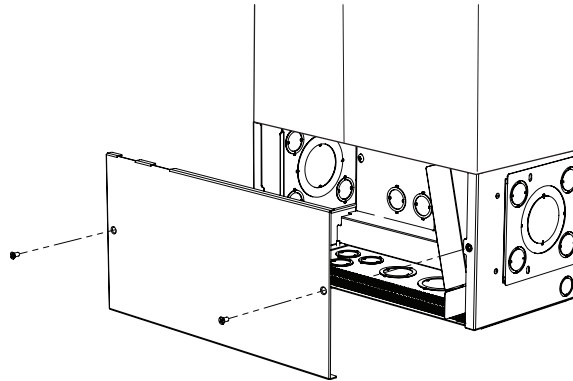


### Installation tip

Do not secure the front panel of the Conduit Box until you have completed all wiring.

**To secure the front panel of the Conduit Box:**

1. Slide the bottom lip of the front panel over the lower edge of the rear panel.
2. Align the two holes in the front panel with the two holes in the back panel.
3. Using two #10-32 screws (included), secure the front panel to the rear panel.

*Figure 21 Conduit Box installation*

## Communications Network Preparation

### **⚠ WARNING**

#### **XANBUS SHOCK HAZARD**

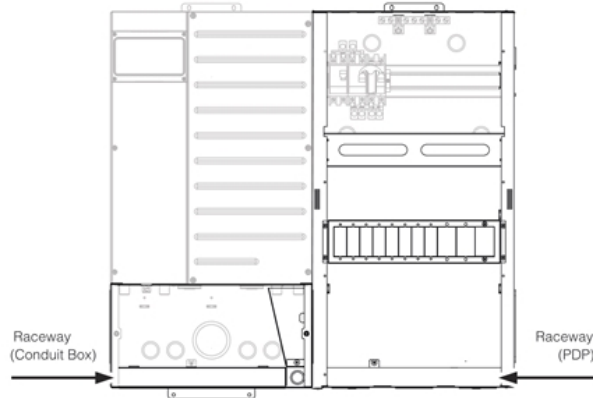
Xanbus cables in contact with DC or AC power can transmit an electric shock. Do not route the Xanbus cables in the same conduit or panel as the AC and DC power cabling.

**Failure to follow these instructions can result in death, serious injury, or equipment damage.**

To separate the communications cables and signal cables from the DC and AC wiring, a raceway (wire barrier) has been included in the design of both the Power Distribution Panel (PDP) and the Conduit Box.

This raceway is built into the bottom of the Power Distribution Panel (PDP) and Conduit Box (see *Pre-Installation*, below) and is held in place by a single screw at the top of each raceway.

*Figure 22 Example of raceways in a single-inverter system*



Before making AC and DC connections, route communication cables (including Battery Temperature Sensor) through the raceways. For easier identification, use a different color for each communications cable, or cable tags.

Connect communications cables to their components after AC and DC connections are made.

## Battery Bank Preparation

<b>⚠ WARNING</b>
<p><b>BATTERY TYPE AND SET UP HAZARDS</b></p> <p>Incorrect battery configurations or settings for battery types can lead to dangerously high battery temperature, fire and explosion.</p> <p>To avoid damaging your batteries during charging or equalization, and to minimize the risk of fire or explosion consult battery manufacture's documentation before setting battery parameters and follow the battery manufacturer's recommended settings.</p> <ul style="list-style-type: none"> <li>■ Always use and connect the Battery Temperature Sensor (BTS).</li> <li>■ Always verify that the configured battery type matches the battery type being used.</li> <li>■ Custom battery settings should be configured by qualified personnel only.</li> <li>■ When using Lithium-Ion batteries, ensure that the battery pack being used includes a Battery Management System (BMS) with safety controls.</li> <li>■ Do not use wet type Lithium-Ion batteries.</li> </ul> <p><b>Failure to follow these instructions can result in death, serious injury, or equipment damage.</b></p>

The Conext XW Pro Inverter/Charger operates with batteries as its source of DC power. If DC power sources are connected directly to the inverter, the DC rating of the inverter can be exceeded and the inverter can be damaged.

<b>NOTICE</b>
<p><b>OTHER SOURCES OF DC POWER</b></p> <p>Do not connect DC power sources, such as PV arrays, wind turbines, or micro-hydro turbines, directly to the Conext XW Pro Inverter/Charger. Connect DC power sources to a charge controller and then to the battery. DC surge protection should also be installed.</p> <p><b>Failure to follow these instructions can result in equipment damage.</b></p>

Choose Flooded, AGM, Gel, Lithium-Ion, or custom batteries for your installation.

Consider the following recommendations for battery use:

- Use only deep cycle types for inverter applications.
- Use the same battery type for all batteries in the bank.
- Use only batteries from the same lot and date in your battery bank. This information is usually printed on a label located on the battery.

## Battery Bank Requirements

The DC voltage of the Conext XW Pro must match the nominal voltage of the system and battery-connected devices. The inverter is a 48 V inverter; therefore, the battery bank and battery-connected devices in the system must be configured for 48 volts.

**Note:** The minimum recommended battery bank is 440 Ah per inverter/charger. The Conext XW Pro is designed to operate with batteries and should not be operated without them. Also, do not allow the battery bank to become completely discharged. If the voltage of the battery bank falls below 40 volts, the Conext XW Pro will not operate.

## Battery Cable Requirements

### WARNING

#### OVERHEATING OF DC TERMINALS AND CABLES

Overheating of the DC terminals or DC cables to dangerous temperatures may occur due to improper installation.

- Do not put anything between the cable lug and the terminal surface.
- Do not over-tighten connections; observe all recommended torque values.
- Do not apply any type of anti-oxidant paste until after the cable connection is tightened.
- Do not under size cables; install cables sized in accordance with national electrical code requirements.
- DC cables must have crimped copper compression lugs or crimped and soldered copper compression lugs; soldered connections alone are not acceptable. Lugs must be rated for use with fine-stranded cable.
- Do not use coarse-stranded cable; the lack of flexibility may pull DC terminal connections loose.

**Failure to follow these instructions can result in death, serious injury, or equipment damage.**

### Battery cable length

Cable runs should be kept as short as practical. Length should not exceed 10 feet (3 m). Run the positive and negative cables alongside each other. Avoid cable loops.

In order to keep the battery cable length short, install the Conext XW Pro as close as possible to the battery room or battery enclosure.

**Note:** For best system performance, ensure that positive and negative battery cables are installed in close proximity to each other.

**Overcurrent protection**

<b>⚠ WARNING</b>
<p><b>DC OVER CURRENT</b></p> <p>The NEC/CEC requires both DC over current protection and a DC disconnect switch for residential and commercial electrical systems. Fuses and disconnects must be sized to protect the wiring in the system and are required to open before the wire reaches its maximum current carrying capability.</p> <p><b>Failure to follow these instructions can result in death, serious injury, or equipment damage.</b></p>

**Terminal covers**

Color-coded snap-on DC terminal covers are included to avoid accidental contact with the terminals. Terminal covers are required for all installations, even if a Conduit Box is used. It is also recommended that the shank of the ring terminals (cable lugs) be covered with heat shrink or some other form of insulation.

**Note:** The NEC/CEC requires both overcurrent protection and a disconnect switch for residential and commercial electrical systems. These items are not supplied as part of the inverter, but are included with the Power Distribution Panel (PDP).

*Table 3 Recommended Battery Cable Size Versus Length*

Inverter Model	Up to 5 Feet (1.5 m) (90°C wire)	Up to 10 Feet (3 m) (90°C wire)
XW Pro 6848 NA	#4/0 AWG (120 mm <sup>2</sup> )	#4/0 AWG (120 mm <sup>2</sup> )

*Table 4 Battery Cable (in Conduit) to Maximum Breaker/Fuse Size*

Cable Size Required	Maximum Breaker/Fuse Size
#4/0 (0000) AWG (120 mm <sup>2</sup> )	250 amps



## Torque Values

### Torque values for the Conext XW Pro

Table 5 Torque Values for AC Wiring (AC Terminals and Ground Bar)

Wire Size		Torque Value	
AWG	mm	In-lb	N-m
14–10	1.63–2.59	35	4.0
8	3.26	40	4.5
6–4	4.11–5.19	45	5.1

Table 6 Torque Values for the Chassis Ground Lug

Wire Size		Torque Value	
AWG	mm	In-lbs	N-m
6–4	4.11–5.19	45	5.1
3–2	5.83–6.54	50	5.6

Table 7 Torque Values for the Inverter Battery Terminals

Torque Value	
Ft-lbs	N-m
15	20.4

### Torque Values for the Power Distribution Panel (PDP)

Table 8 Torque Values for AC Disconnects and AC Breakers

Wire Size		Torque Value	
AWG	mm	In-lb	N-m
16–10	1.29–2.59	45	5.1
8	3.26	45	5.1
6–4	4.11–5.19	45	5.1

Table 9 Torque Values for the Ground Bus, AC Neutral Bus, DC Negative Bus, and DC Positive Bus in the PDP

Wire Size		Torque Value	
AWG	mm	In-lbs	N-m
14–10	1.63–2.59	35	4.0
8	3.26	40	4.5
6–4	4.11–5.19	45	5.1
3–2/0	5.83–9.27	50	5.6

*Table 10 Torque Values for the power distribution jumpers in the PDP*

Wire Size		Torque Value	
AWG	mm	In-lbs	N-m
14–10	1.63–2.59	35	4.0
8	3.26	40	4.5
6–4	4.11–5.19	45	5.1
3–2/0	5.83–9.27	50	5.6

*Table 11 Torque Values for the Battery Cables to the DC Negative Bus, and DC Positive Bus in the PDP*

Torque Value	
Ft-lbs	N-m
15	20.4

## 3 Wiring

### What's in This Chapter?

<b>Removing the AC Access Panel and PDP Internal Faceplates</b> .....	<b>43</b>
AC Access Panel Removal .....	43
Conext XW Pro Power Distribution Panel Internal Faceplate Removal .....	44
<b>Communication Ports and BTS Port</b> .....	<b>46</b>
AUX Port .....	46
<b>Wiring the Conext XW Pro with a PDP</b> .....	<b>49</b>
Conext XW Pro Inverter/Charger Grounding .....	49
Grounding the DC System .....	49
Battery Temperature Sensor Installation .....	51
Making DC Connections .....	52
Making AC Connections .....	56
AC System Bonding .....	59
<b>Basic Functional Test – Single Inverter</b> .....	<b>67</b>
Confirming All Connections .....	67
Applying DC Power to the Inverter .....	68
Enabling the Inverter .....	68
AC Voltage Check .....	71
Confirming Battery Charger Operation .....	71
Conext XW Pro Inverter/Charger Grounding .....	73
<b>Wiring the Conext XW Pro Inverter/Charger without a PDP</b> .....	<b>73</b>
Pre-Installation Steps .....	74
Feed-in Protection Requirements .....	75
Conext XW Pro Inverter/Charger Grounding .....	75
Grounding the DC System .....	76

# Removing the AC Access Panel and PDP Internal Faceplates

## AC Access Panel Removal

### **DANGER**

#### **HAZARD OF ELECTRIC SHOCK, EXPLOSION, ARC FLASH, AND FIRE**

- Apply appropriate personal protective equipment (PPE) and follow safe electrical work practices. See NFPA 70E or CSA Z462.
- This equipment must only be installed and serviced by qualified electrical personnel.
- Never operate energized with covers removed
- Energized from multiple sources. Before removing covers identify all sources, de-energize, lock-out, and tag-out and wait 2 minutes for circuits to discharge
- Always use a properly rated voltage sensing device to confirm all circuits are de-energized.

**Failure to follow these instructions will result in death or serious injury.**

### **DANGER**

#### **HAZARD OF ELECTRIC SHOCK, EXPLOSION, ARC FLASH, AND FIRE**

- Remove watches, rings, or other metal objects.
- This equipment must only be installed and serviced by qualified electrical personnel.
- Keep sparks and flames away from the batteries.
- Use tools with insulated handles.
- Wear protective glasses, gloves and boots.
- Do not lay tools or other metal parts on top of batteries.

**Failure to follow these instructions will result in death or serious injury.**

### **DANGER**

#### **HAZARD OF ELECTRIC SHOCK, EXPLOSION, ARC FLASH, AND FIRE**

- Battery Circuit Breakers must be installed according to the specifications and requirements defined by Schneider Electric.
- Servicing of batteries must only be performed by qualified personnel knowledgeable of batteries and the required precautions. Keep unqualified personnel away from batteries.
- Disconnect the charging source prior to connecting or disconnecting battery terminals.

**Failure to follow these instructions will result in death or serious injury.**

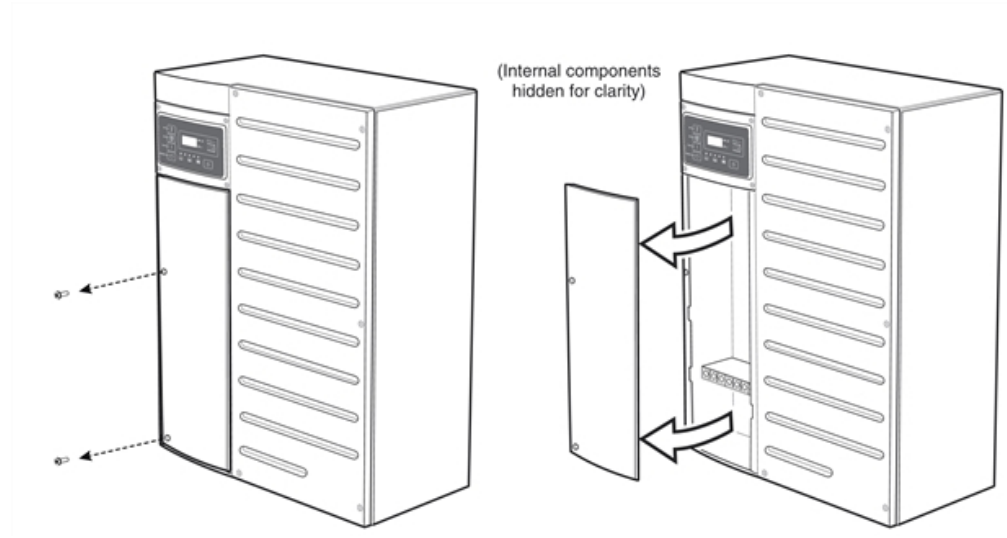
To access the AC terminal block on the Conext XW Pro for AC wiring, you will need to remove the AC access panel, located below the inverter information panel on the left side of the Conext XW Pro chassis.

To remove the AC access panel, remove the two screws from the AC access cover and slide the cover slightly to the left and lift away from the Conext XW Pro chassis.

#### Installation tip

When re-securing the AC access cover, ensure its recessed edge slips inside the edge of the front panel.

Figure 23 AC access panel removal



## Conext XW Pro Power Distribution Panel Internal Faceplate Removal

If you are wiring the Conext XW Pro to a Power Distribution Panel (PDP), you will need to remove the two front faceplates from the PDP.

For easier access to the faceplates, begin by removing the panel door from its hinges.

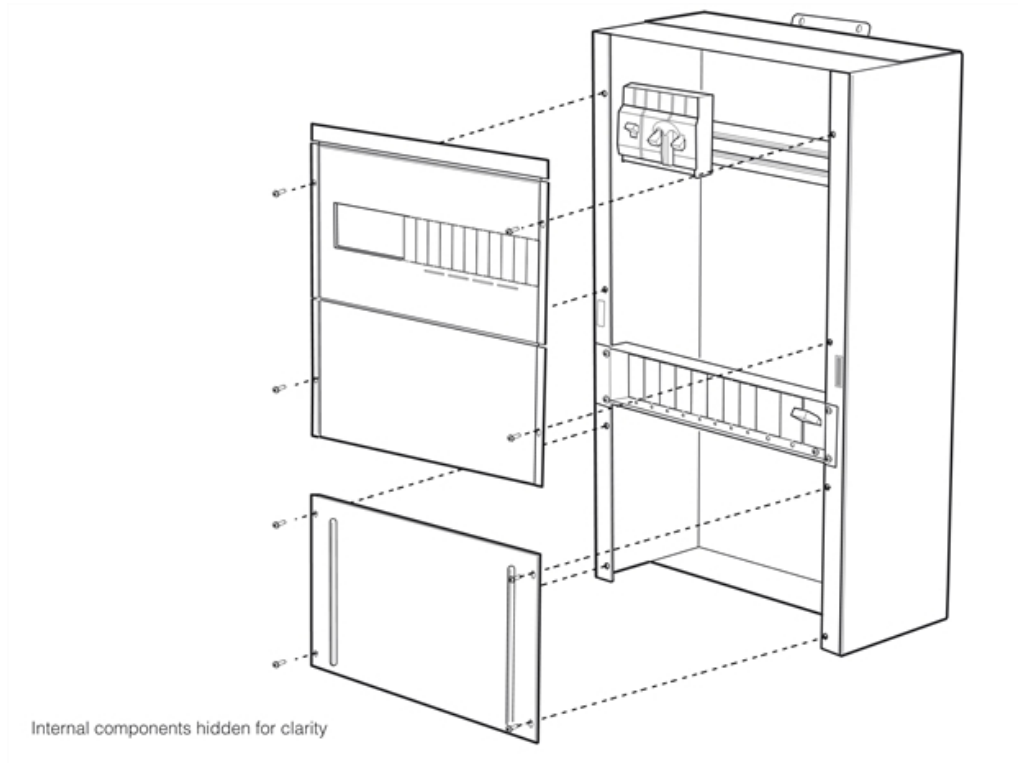
#### To remove the PDP door:

1. Remove the screw at the top hinge of the PDP door and remove the top section of the hinge.
2. Using your thumb or forefinger, gently pivot the hinge upward as you remove the PDP door.

#### To remove the PDP faceplates:

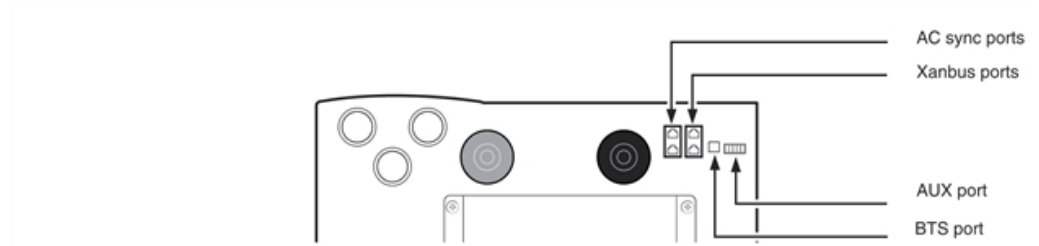
1. Remove the four screws holding the upper faceplate in place.
2. Remove the four screws holding the lower faceplate in place.

Figure 24 Power Distribution Panel (PDP) faceplate removal



## Communication Ports and BTS Port

Figure 25 Conext XW Pro communication ports



There are five communication ports and a Battery Temperature Sensor (BTS) port located on the bottom of the Conext XW Pro chassis (as shown above in *Removing the AC Access Panel and PDP Internal Faceplates*):

- Two Power Distribution Panel (without AC Breakers) ports for making network connections between inverters, charge controllers, and accessories. For more information, see *"The Xanbus Network"* on page 83.
- AUX port: 12 VDC/250 mA output to control a relay, fan, indicator light, or other device, using a Conext SCP. For more information, see *Removing the AC Access Panel and PDP Internal Faceplates* on page 43.
- Battery Temperature Sensor (BTS) port: For more information, see *Removing the AC Access Panel and PDP Internal Faceplates* on page 43.

## AUX Port

The Conext XW Pro has a 12 VDC auxiliary (AUX) output that can be configured to trigger in response to one of the following conditions:

- low battery voltage
- high battery voltage
- low battery temperature
- high battery temperature
- charge bulk exit
- charge absorption exit
- heatsink temperature
- TOD (time of day)
- SOC (state of charge)

The auxiliary output can also be triggered manually using a Conext SCP.

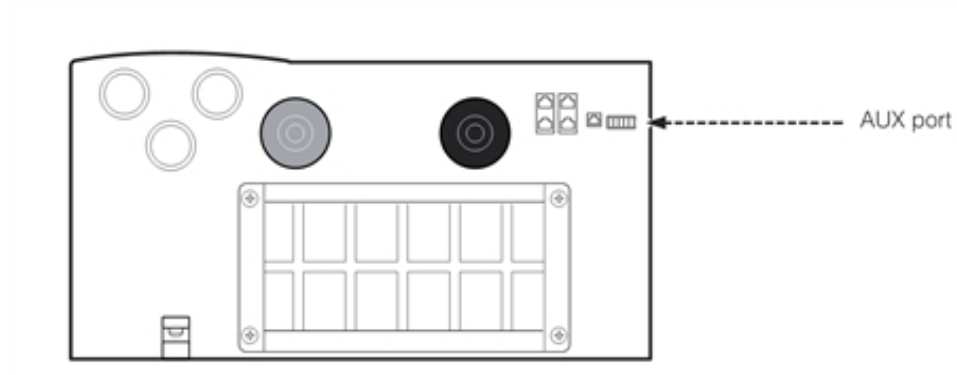
**Note:** The AUX port is connected via an AUX port connector, included with the Conext XW Pro.

The 12 VDC output can be used to trigger a relay to disconnect batteries from the inverter/charger when battery voltage or temperature are out of range.

The auxiliary output is also designed to provide the following functions:

- Auxiliary 12 VDC power supply. See AUX+12V Voltage Supply, below.
- Remote Power Off. See AUX-RPO: User Remote Power OFF (RPO), below.

Figure 26 AUX Port Location



## AUX+12V Voltage Supply

DC voltage is available between JU-1 (AUX +12 V) and JU-3 (AUX-COM, signal return). The power available at these terminals is 12 VDC and maximum current is 250 mA (3 watts).

AUX+12 V and AUX-COM terminals can be used to power a relay (3wattsmaximum).

**Note:** Additional fuses may be necessary for some installations.

AUX +12 V voltage supply can be programmed for different tasks ON and OFF using the Conext SCP.

Default status of AUX+12 V is OFF.

## AUX-RPO: User Remote Power OFF (RPO)

Connecting JU-2 (AUX-RPO) and JU-3 (AUX-COM) terminals together through an external switch (normal open contact) will provide the system shut off function if the switch is closed. The external switch, if pressed, overrides the control provided from the front panel.

To enable the AUX port remote power off function, enable the RPO setting from the System Control Panel. For more information, see the Owner's Guide. If the external switch is cleared (not pressed), the system can be enabled back from the front panel.

Select an external switch with normal open contact; consult your local system designer or qualified technician for specific installation instructions.

## User Line Wiring

Use twisted pairs of #24 AWG to #12 AWG (0.51mm to 2.05mm) for connections. Carefully route the wires away from high power load cables to minimize noise effects on signal integrity.



## AUX Port Terminal Assignments

Table 12 User Connector Terminals and Functions

Pin	Reference	Name	Function
JU-1	AUX+12V	+12 V User Voltage Supply	+12 VDC Voltage source: 250 mA maximum
JU-2	AUX-RPO	Remote Power Off	Remote Power Off Logic Level: Active Low. Activating this signal shuts down system operation
JU-3	AUX-COM	Common Ground Reference	Return Common Ground Reference for 12 V, Remote Power Off signals
JU-4	EXT_TS_OUT	External Transfer switch: Output signal	Open collector type drive circuit (30V/0.5A max)
JU-5	EXT_TS_IN	External Transfer switch: Input signal	External Transfer switch: Low signal range:(0-5V) High signal range:10-28V with the consumption of 8mA@12V and 10mA@24V

## Wiring the Conext XW Pro with a PDP

### NOTICE

#### OVERLOADING THE DISTRIBUTION PANEL

The amount of power that can be fed into a distribution panel and the means and location for feed-in, must be in accordance with NEC 2008 article 690.64 or the current requirements of the local electrical code.

**Failure to follow these instructions can result in equipment damage.**

This section provides instructions for making AC and DC connections between the Conext XW Pro Inverter/Charger and an Power Distribution Panel (PDP), using a Conduit Box Conduit Box and the pre-installed cables in the PDP.

To install a Conext XW Pro without the Conduit Box or PDP, see *Wiring the Conext XW Pro Inverter/Charger without a PDP on page 73* of this Guide.

**Note:** If a Conduit Box is installed, run the communication and Battery Temperature Sensor cables through the raceway at the rear of the Conduit Box and PDP before making AC and DC connections. The raceways become more difficult to access after AC and DC wiring is completed. For more information, see *Pre-Installation on page 27* of this Installation Guide.

## Conext XW Pro Inverter/Charger Grounding

### ⚠ WARNING

#### UNGROUNDING EQUIPMENT

Equipment ground terminals must be reliably connected to ground by appropriately sized grounding conductors. All installations must comply with national and local codes. Consult local and national codes for specific grounding and bonding requirements.

**Failure to follow these instructions can result in death, serious injury, or equipment damage.**

The Conext XW Pro is provided with ground terminals that must be reliably connected to ground (protective earth) by appropriately sized equipment grounding conductors. System grounding for the AC and DC systems must be done according to all applicable NEC and local installation codes.

For more information about system grounding, see *Removing the AC Access Panel and PDP Internal Faceplates on page 43* and *Removing the AC Access Panel and PDP Internal Faceplates on page 43*.

## Grounding the DC System

To connect the Conext XW Pro to the DC grounding system, use the ground lug at the bottom of the Conext XW Pro chassis (see *Conext XW Pro Features on page 20*). The terminal accepts wires from #14 AWG (1.63 mm) to #2AWG (6.54 mm).

System grounding for the DC system, which typically involves bonding (connecting) the battery negative circuit to ground, is dependent on the system configuration.

**⚠ WARNING**

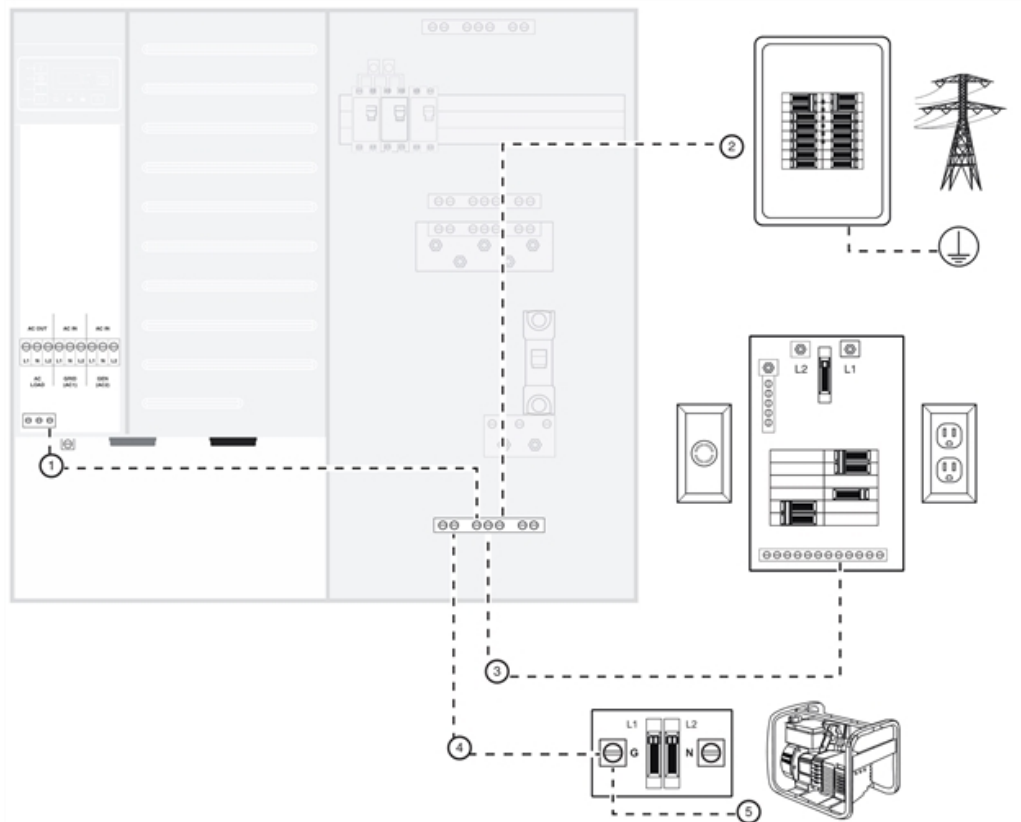
**LACK OF GROUND FAULT DETECTION HAZARD**

Ground fault detection on the MPPT 60 150 solar charge controller is circumvented when the Conext XW Pro battery negative circuit is grounded.

**Failure to follow these instructions can result in death, serious injury, or equipment damage.**

**Note:** If a grounded DC system is required, ensure that the system bonding is done in one location only, and that all conductors and connections comply with all applicable NEC and local installation codes.

Figure 27 DC Grounding Using a Power Distribution Panel (PDP)



**DC Terminal Connections**

1. To AC ground bar

Note: May not be required if DC ground is used instead.

2. To main utility panel

3. To inverter load sub-panel

4. To generator disconnect

Note: Depending on the location of the generator and local code requirements, the generator disconnect may be located in the power distribution panel.

5. To AC generator

Grounding requirements may vary.

Cable routing may vary. See Knockout Selection on page 2-5 and Communications Network Preparation on page 2-12.

For torque values, see page 2-16 and 2-17.

## Battery Temperature Sensor Installation

### **WARNING**

#### **BATTERY TEMPERATURE**

- The Battery Temperature Sensor provides necessary information for performance and safety.
- Always install and connect the Battery Temperature Sensor (BTS). See the note directly below.

**Failure to follow these instructions can result in death, serious injury, or equipment damage.**

**Note:** For all BTS compatible Xanbus enabled devices in the system, at least one BTS must be separately installed for each device type associated with a battery. See the installation guide of each device for BTS installation instructions.

The Battery Temperature Sensor (BTS) regulates battery charging based on battery temperature. The BTS extends battery life by minimizing overcharging in warm temperatures and undercharging in cold temperatures.

The BTS connects to the Conext XW Pro via the BTS port, which is located at the bottom of the Conext XW Pro chassis, next to the communication ports.

**Note:** Connect the BTS to the batteries only after the battery bank has been prepared and is ready to connect to the inverter.

#### **To install the Battery Temperature Sensor:**

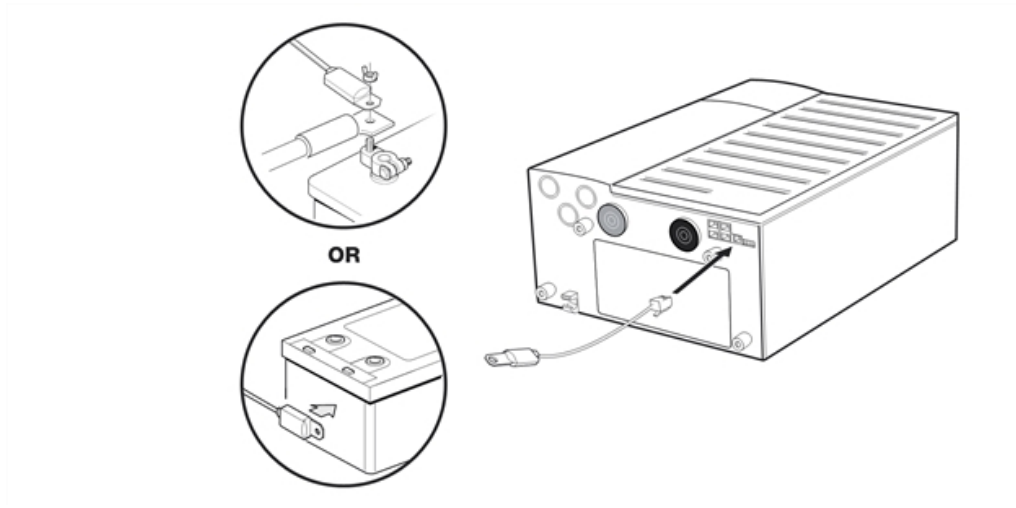
1. Route the BTS cable through your preferred conduit route and insert the BTS jack into the BTS port.
2. Route the BTS cable to the battery enclosure, and then connect the BTS using one of the following methods (as shown in *Removing the AC Access Panel and PDP Internal Faceplates on page 43*):
3. Connect the BTS ring terminal directly to a battery terminal (recommended), or:
4. Attach the BTS to any side of the battery you wish to monitor by using the adhesive backing on the BTS.

**Note:** When using the adhesive backing, install the BTS on the side of the battery below the electrolyte level.

#### **Installation tip**

Place the sensor between batteries and place the batteries in an insulated box to reduce the influence of the ambient temperature outside the battery enclosure.

Figure 28 Battery Temperature Sensor Installation



## Making DC Connections

### Battery cables

#### **DANGER**

##### HAZARD OF ELECTRIC SHOCK, EXPLOSION, ARC FLASH, AND FIRE

- Apply appropriate personal protective equipment (PPE) and follow safe electrical work practices. See NFPA 70E or CSA Z462.
- This equipment must only be installed and serviced by qualified electrical personnel.
- Never operate energized with covers removed
- Energized from multiple sources. Before removing covers identify all sources, de-energize, lock-out, and tag-out and wait 2 minutes for circuits to discharge
- Always use a properly rated voltage sensing device to confirm all circuits are de-energized.


**Failure to follow these instructions will result in death or serious injury.**

#### **DANGER**

##### HAZARD OF ELECTRIC SHOCK, EXPLOSION, ARC FLASH, AND FIRE

- Remove watches, rings, or other metal objects.
- This equipment must only be installed and serviced by qualified electrical personnel.
- Keep sparks and flames away from the batteries.
- Use tools with insulated handles.
- Wear protective glasses, gloves and boots.
- Do not lay tools or other metal parts on top of batteries.


**Failure to follow these instructions will result in death or serious injury.**

** DANGER**

**HAZARD OF ELECTRIC SHOCK, EXPLOSION, ARC FLASH, AND FIRE**

- Battery Circuit Breakers must be installed according to the specifications and requirements defined by Schneider Electric.
- Servicing of batteries must only be performed by qualified personnel knowledgeable of batteries and the required precautions. Keep unqualified personnel away from batteries.
- Disconnect the charging source prior to connecting or disconnecting battery terminals.

**Failure to follow these instructions will result in death or serious injury.**

** WARNING**

**OVERHEATING OF DC TERMINALS AND CABLES**

Overheating of the DC terminals or DC cables to dangerous temperatures may occur due to improper installation.

- Do not put anything between the cable lug and the terminal surface.
- Do not over-tighten connections; observe all recommended torque values.
- Do not apply any type of anti-oxidant paste until after the cable connection is tightened.
- Do not under size cables; install cables sized in accordance with national electrical code requirements.
- DC cables must have crimped copper compression lugs or crimped and soldered copper compression lugs; soldered connections alone are not acceptable. Lugs must be rated for use with fine-stranded cable.
- Do not use coarse-stranded cable; the lack of flexibility may pull DC terminal connections loose.

**Failure to follow these instructions can result in death, serious injury, or equipment damage.**

**NOTICE**

**DC REVERSE POLARITY**

Before making the final DC connection or closing the DC breaker or disconnect, check cable polarity at both the battery and the inverter/charger. Positive (+) must be connected to positive (+). Negative (-) must be connected to negative (-).

**Failure to follow these instructions can result in equipment damage.**

Battery cables are not included in the Conext XW Pro package. Depending on your installation requirements, you will need to supply at least one pair of battery cables. For battery cable requirements, see *Battery Cable Requirements on page 38*.

**Note:** One pair of #4/0 AWG Arctic Ultraflex Blue™ battery cables is included with each Power Distribution Panel (PDP) and Connection Kit for INV2 INV3 PDP. For more information, see *Overview on page 19*.

Figure 29 Battery terminals (bottom of Conext XW Pro)

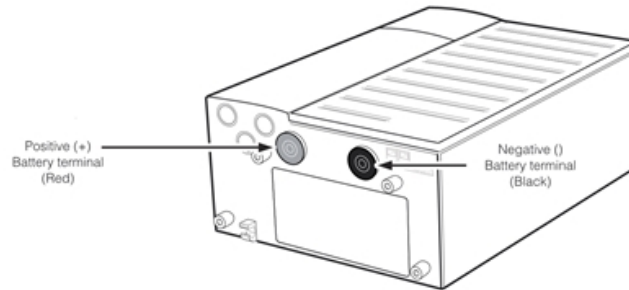
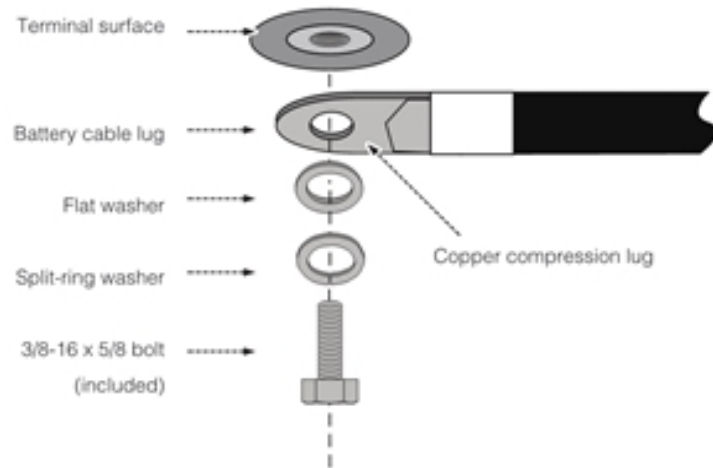


Figure 30 Battery cable connection



**To connect the Power Distribution Panel (PDP) to the Conext XW Pro:**

1. Connect the positive battery cable (pre-installed in the PDP) to the positive battery terminal at the bottom of the Conext XW Pro, as shown in *Removing the AC Access Panel and PDP Internal Faceplates on page 43*.
2. Connect the negative battery cable (pre-installed in the PDP) to the negative battery terminal at the bottom of the Conext XW Pro.

**Note:** When making the connections, be sure to observe correct hardware stacking and proper polarity, and ensure that nothing obstructs the connection between the terminal surface and the battery cable lug. (See *Removing the AC Access Panel and PDP Internal Faceplates on page 43*.)

3. Attach the DC terminal covers (included with the Conext XW Pro) to the bottom of the Conext XW Pro DC terminals.

**To connect the PDP to the Battery Bank:**

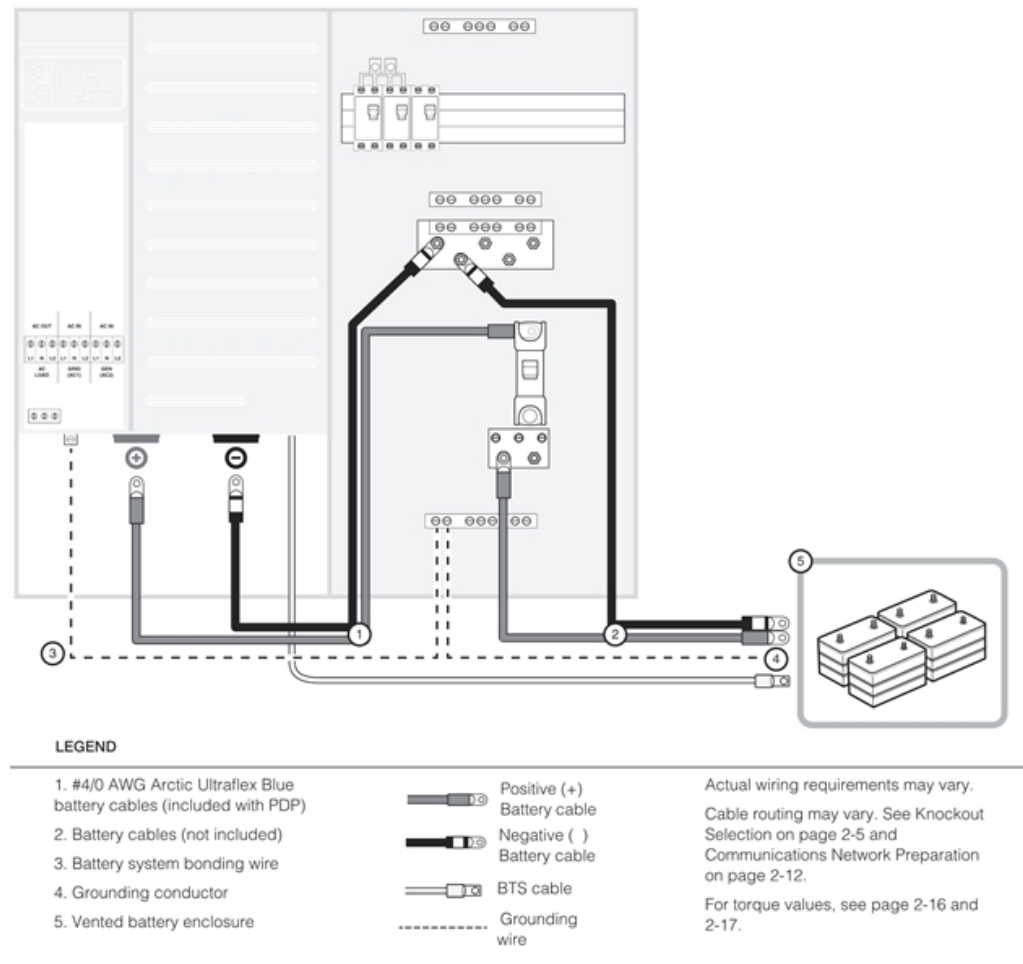
Connect your battery cables (not included) to the PDP. Connect the negative battery cable to the DC Negative Bus, and the positive battery cable to the input end of the GJ250A 160 VDC, 3/8" stud DC breaker (pre-installed in the PDP), as shown in *Removing the AC Access Panel and PDP Internal Faceplates on page 43*.

**Note:** To properly attach and torque the positive cable to the DC breaker, you may need to temporarily remove the breaker from the rail.

Route your battery cables from the PDP, through your preferred conduit path, to the battery location. Do not connect the cables to the battery yet.

**Note:** Before connecting the DC cables from the PDP to the battery, perform the procedures in *Removing the AC Access Panel and PDP Internal Faceplates on page 43*.

*Figure 31 DC Connections to a Single Inverter Using a PDP*





## Making AC Connections

This section provides instructions for making AC connections between the Conext XW Pro and the Power Distribution Panel (PDP) (using the pre-installed AC cables in the PDP) and between the PDP and your inverter load sub-panel.

**Note:** Install an inverter load sub-panel and AC conduit before completing your Conext XW Pro installation. For more information, see *Removing the AC Access Panel and PDP Internal Faceplates* on page 43.

**Note:** Do not use a GFCI equipped AC source to power either the Grid (AC1) or Generator (AC2) inputs. The AC input filters on the Conext XW Pro may cause nuisance tripping of ground fault protected outputs.

### NOTICE

#### BACK FED AC POWER

Back fed AC Power can damage equipment. Do not wire the inverter's AC output port directly to the utility line or generator output.

**Failure to follow these instructions can result in equipment damage.**

**Note:** Wiring the inverter's AC output to the utility or generator output will cause severe damage to the inverter which is not covered under warranty.

## AC Terminal Block

### DANGER

#### HAZARD OF ELECTRIC SHOCK, EXPLOSION, ARC FLASH, AND FIRE

- Apply appropriate personal protective equipment (PPE) and follow safe electrical work practices. See NFPA 70E or CSA Z462.
- This equipment must only be installed and serviced by qualified electrical personnel.
- Never operate energized with covers removed
- Energized from multiple sources. Before removing covers identify all sources, de-energize, lock-out, and tag-out and wait 2 minutes for circuits to discharge
- Always use a properly rated voltage sensing device to confirm all circuits are de-energized.

**Failure to follow these instructions will result in death or serious injury.**

**⚡ ⚠ DANGER**

**HAZARD OF ELECTRIC SHOCK, EXPLOSION, ARC FLASH, AND FIRE**

- Remove watches, rings, or other metal objects.
- This equipment must only be installed and serviced by qualified electrical personnel.
- Keep sparks and flames away from the batteries.
- Use tools with insulated handles.
- Wear protective glasses, gloves and boots.
- Do not lay tools or other metal parts on top of batteries.

**Failure to follow these instructions will result in death or serious injury.**

**⚡ ⚠ DANGER**

**HAZARD OF ELECTRIC SHOCK, EXPLOSION, ARC FLASH, AND FIRE**

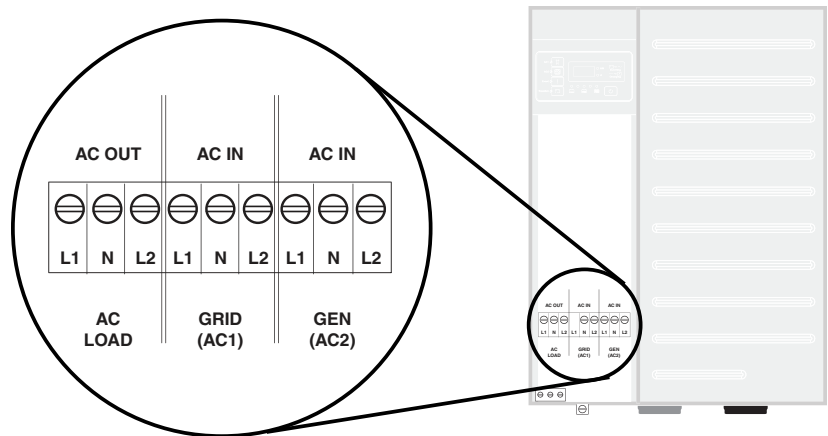
- Battery Circuit Breakers must be installed according to the specifications and requirements defined by Schneider Electric.
- Servicing of batteries must only be performed by qualified personnel knowledgeable of batteries and the required precautions. Keep unqualified personnel away from batteries.
- Disconnect the charging source prior to connecting or disconnecting battery terminals.

**Failure to follow these instructions will result in death or serious injury.**

To access the AC terminal block, you will need to remove the AC access panel. For more information, see *Removing the AC Access Panel and PDP Internal Faceplates on page 43*.

The AC terminal block includes three terminals each (L1, L2, and Neutral) for AC Grid input (AC1), AC Generator input (AC2), and AC Out (AC LOAD) connections. (see *Removing the AC Access Panel and PDP Internal Faceplates on page 43*.)

Figure 32 AC terminal block

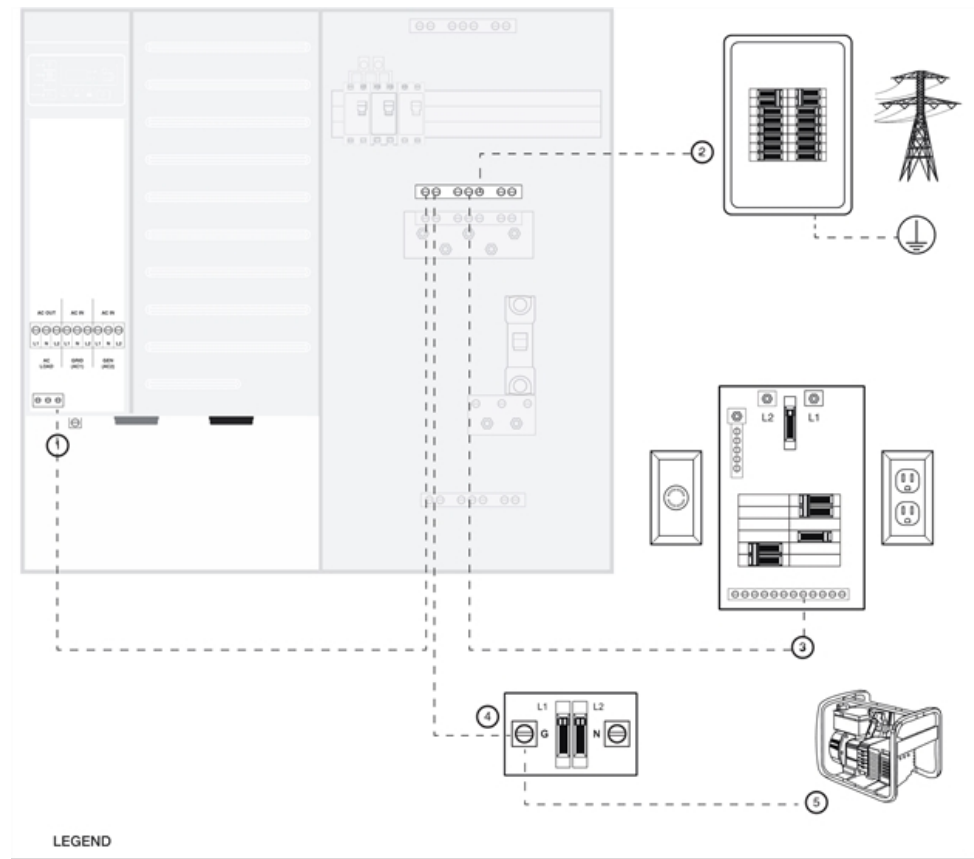


The neutral inputs are connected to each other, requiring only one neutral connection when installed with a Power Distribution Panel (PDP). Without the PDP, additional neutral connections may be required at the input sources.

### AC Equipment Grounding

See *Pre-Installation on page 27* for torque values for the AC terminal and AC ground bar. See *Pre-Installation on page 27* for torque requirements for the ground bar in the Conext XW Pro Power Distribution Panel.

Figure 33 AC Equipment Grounding With the PDP



**LEGEND**

1. To AC ground bar  
 2. To main utility panel  
 3. To inverter load sub-panel  
 Note: May not be required if DC ground is used instead.

4. Generator disconnect  
 Note: Depending on the location of the generator and local code requirements, the generator disconnect may be located in the power distribution panel.  
 5. To AC generator

Grounding requirements may vary.  
 Cable routing may vary. See Knockout Selection on page 2-5 and Communications Network Preparation on page 2-12. For torque values, see page 2-16 and 2-17.

## AC System Bonding

### **WARNING**

#### **MULTIPLE AC NEUTRAL-TO-GROUND BONDS**

Verify that only one neutral-to-ground bond exists in the system. Having more than one neutral-to-ground bond in a system violates local electrical codes, may create a shock or fire hazard, and may cause some sensitive equipment to malfunction.

**Failure to follow these instructions can result in death, serious injury, or equipment damage.**

System bonding refers to connection (bonding) of one of the current-carrying conductors of an electrical system to ground. This creates a "grounded conductor" or "neutral" that is at ground potential, but is separate from the equipment ground conductor. System bonding must be done at only one location. Procedures for system bonding vary between on-grid and off-grid systems.

#### **System bonding for on-grid systems**

The Conext XW Pro does not connect the neutral to ground. The AC input neutral is already bonded to ground by the incoming utility grid system. Do not connect the neutral to ground in any additional location.

The Conext XW Pro does not switch or disconnect the AC neutral in any mode of operation, so even in invert (back-up) mode, the inverter load sub-panel neutral is bonded to ground by the utility grid system. It must not be grounded again in the inverter load sub-panel.

#### **System bonding for off-grid systems**

In a system without a generator, or with a generator that does not provide a grounded neutral, you must make the connection from neutral to ground in the inverter load sub-panel or main distribution panel, as applicable.

In a system with a generator that provides a grounded neutral, no additional connection from neutral to ground is needed. Do not connect neutral to ground in the inverter load sub-panel or main distribution panel, as applicable.

## AC wiring the Power Distribution Panel (PDP) to the Conext XW Pro

### To connect the Power Distribution Panel (PDP) to the Conext XW Pro:

1. In the Power Distribution Panel (PDP), locate the wire labelled INV1 N-LOAD (SPLIT PHASE), pre-installed in the neutral bus bar N-LOAD terminal. Connect the INV1 N-LOAD (SPLIT PHASE) wire to the AC Load terminal (N-LOAD) on the Conext XW Pro, as shown in *Removing the AC Access Panel and PDP Internal Faceplates on page 43*.
2. Locate the wires labelled INV1 L1-LOAD and INV1 L2-LOAD, pre-installed in the terminals at the input (top) side of the 60 A, 120/240 VAC, two-pole, type QOU output AC breaker in the PDP. Connect the INV1 L1-LOAD and INV1 L2-LOAD wires to the AC Load terminals (L1 -LOAD and L2-LOAD, respectively) on the Conext XW Pro.
3. Locate the wires labelled INV1 L1-GRID and INV1 L2-GRID, pre-installed in the terminals at the bottom of the output breaker in the PDP.
4. Connect the INV1 L1-GRID and INV1 L2-GRID to the Conext XW Pro, using one of the following methods (depending on your installation):
  - If the AC source will be the utility grid, connect to the GRID (AC1) terminals (L1-GRID, L2-GRID) on the Conext XW Pro Inverter/Charger. (See *Removing the AC Access Panel and PDP Internal Faceplates on page 43*.)

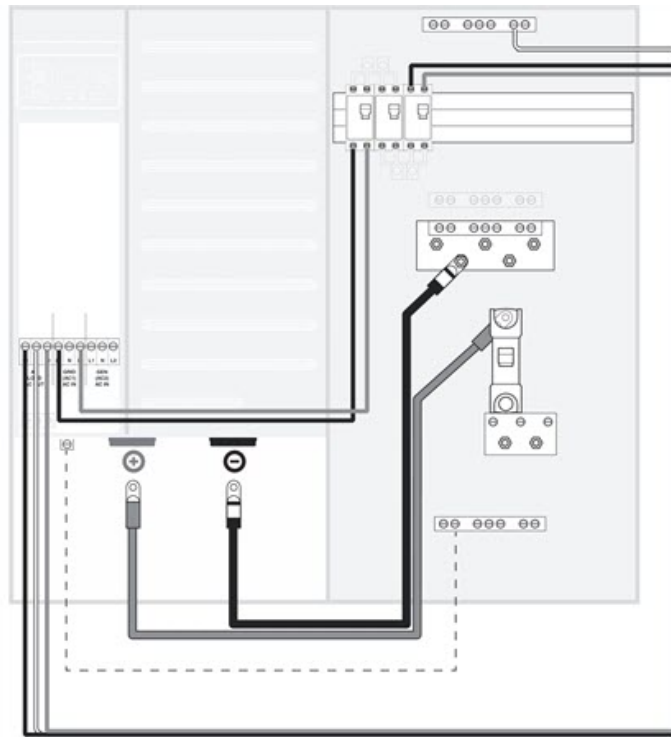
**Note:** In an on-grid system with a generator, you will need to install an additional 60 A, 120/240 VAC, two-pole, type QOU AC breaker onto the DIN rail. For information, see *Removing the AC Access Panel and PDP Internal Faceplates on page 43*.

- If the system will be off-grid and the only AC source will be a generator, connect these wires to the GEN (AC2) terminals (L1-GEN, L2-GEN) on the Conext XW Pro Inverter/Charger.

**Note:** Both lines (L1 and L2) of input power must be connected in order for the Conext XW Pro to operate. For example, L1 and L2 of Grid Input L1 and L2 of Gen Input need to be connected.

**Note:** Additional neutral terminals (N-GRID, N-GEN) are provided on the Conext XW Pro for installations that do not use the Power Distribution Panel. For more information, see *Wiring the Conext XW Pro Inverter/Charger without a PDP on page 73*.

Figure 34 Wiring the Conext Power Distribution Panel (PDP) to the Conext XW Pro



LEGEND

- Grounding wire
- ==== Neutral
- Hot L1  
— Hot L2

- Positive (+) Battery cable
- Negative (-) Battery cable

Actual wiring requirements may vary.

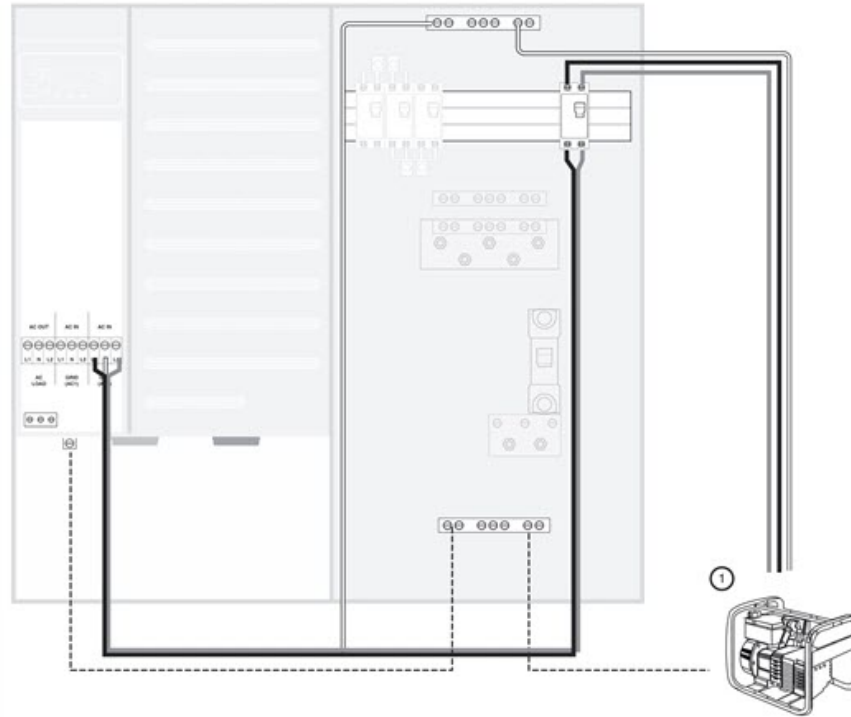
Cable routing may vary. See sections on Knockout Selection and Communications Network Preparation.

See section on Torque Requirements for torque values.

### Wiring the Power Distribution Panel (PDP) to a Generator (On-Grid)

In an on-grid installation, the generator will require an additional 60 A, 120/240 VAC, two-pole, type QOU AC breaker to be installed in the Power Distribution Panel (PDP).

Figure 35 Wiring the Conext XW Pro Power Distribution Panel to a Generator (On-Grid)



**LEGEND**

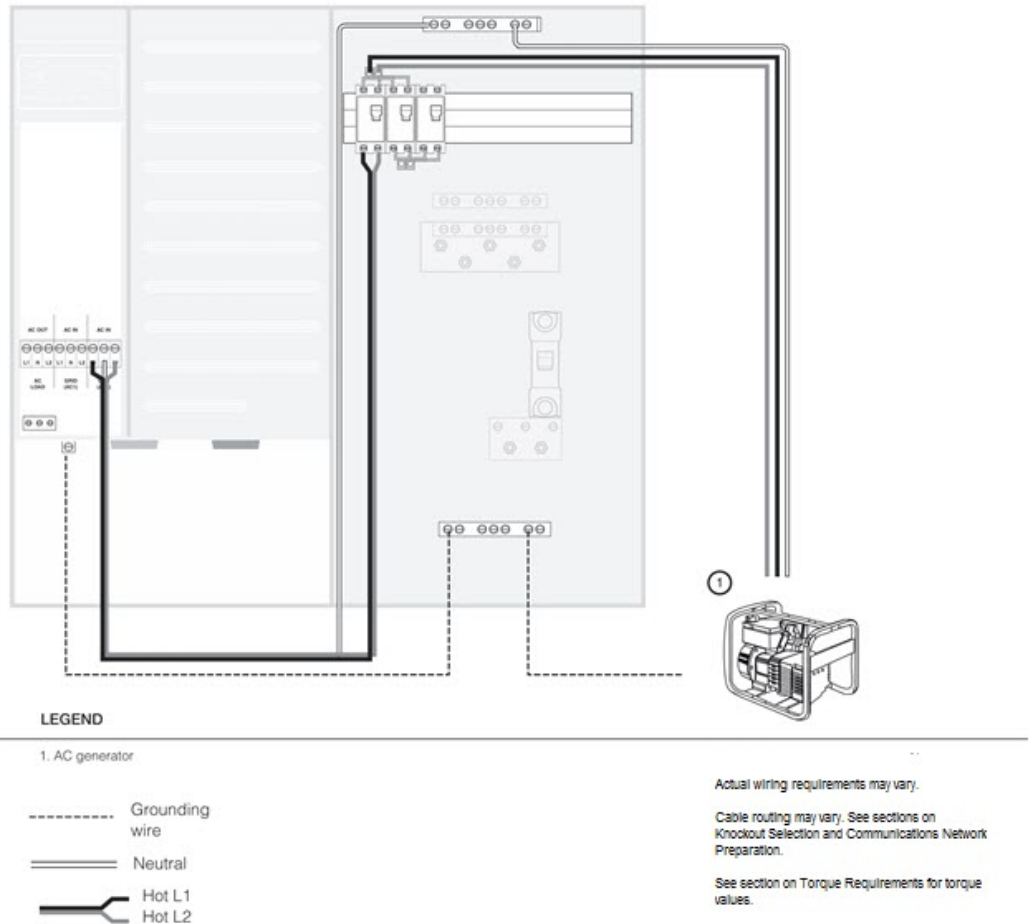
- 1. AC generator
- Grounding wire
- ==== Neutral
- Hot L1
- Hot L2

Actual wiring requirements may vary.  
 Cable routing may vary. See sections on Knockout Selection and Communications Network Preparation.  
 See section on Torque Requirements for torque values.

### Wiring the Power Distribution Panel (PDP) to a Generator (Off-Grid)

In an off-grid installation, the generator can be connected to the breakers provided in the PDP. No additional breaker is required.

Figure 36 Wiring the PDP to a Generator (Off Grid)





## AC Wiring to the Inverter Load Sub-Panel

### **DANGER**

#### **HAZARD OF ELECTRIC SHOCK, EXPLOSION, ARC FLASH, AND FIRE**

- Apply appropriate personal protective equipment (PPE) and follow safe electrical work practices. See NFPA 70E or CSA Z462.
- This equipment must only be installed and serviced by qualified electrical personnel.
- Never operate energized with covers removed
- Energized from multiple sources. Before removing covers identify all sources, de-energize, lock-out, and tag-out and wait 2 minutes for circuits to discharge
- Always use a properly rated voltage sensing device to confirm all circuits are de-energized.

**Failure to follow these instructions will result in death or serious injury.**

### **DANGER**

#### **HAZARD OF ELECTRIC SHOCK, EXPLOSION, ARC FLASH, AND FIRE**

- Remove watches, rings, or other metal objects.
- This equipment must only be installed and serviced by qualified electrical personnel.
- Keep sparks and flames away from the batteries.
- Use tools with insulated handles.
- Wear protective glasses, gloves and boots.
- Do not lay tools or other metal parts on top of batteries.

**Failure to follow these instructions will result in death or serious injury.**

### **DANGER**

#### **HAZARD OF ELECTRIC SHOCK, EXPLOSION, ARC FLASH, AND FIRE**

- Battery Circuit Breakers must be installed according to the specifications and requirements defined by Schneider Electric.
- Servicing of batteries must only be performed by qualified personnel knowledgeable of batteries and the required precautions. Keep unqualified personnel away from batteries.
- Disconnect the charging source prior to connecting or disconnecting battery terminals.

**Failure to follow these instructions will result in death or serious injury.**

An inverter load sub-panel and AC conduit must be installed before your Conext XW Pro installation can be completed.

## Wiring

Wiring for connections between the PDP and the inverter load sub-panel is not included. Power distribution jumpers in the PDP accept up to a #2/0 AWG (9.27mm) cable (maximum).

See *Pre-Installation on page 27* for torque requirements.

### To install the inverter load sub-panel and AC conduit:

1. Choose a location for the inverter load sub-panel and install it according to the manufacturer's directions.
2. Install an AC conduit between the PDP and the inverter load sub-panel.
3. Determine which circuits the Conext XW Pro will power and install the appropriate circuit breakers into the inverter load sub-panel.
4. For on-grid systems:
  - a. Disconnect all power to the main AC panel (utility grid).
  - b. Choose which circuits will be backed by the inverter(s), and remove their wires from the main panel.
  - c. Reroute these wires to the new inverter load sub-panel.
5. Remove unused breakers from utility panel.
6. Install a 60 amp maximum (disconnect) main circuit breaker in the inverter load sub-panel.

### **NOTICE**

#### **BACK FED AC POWER**

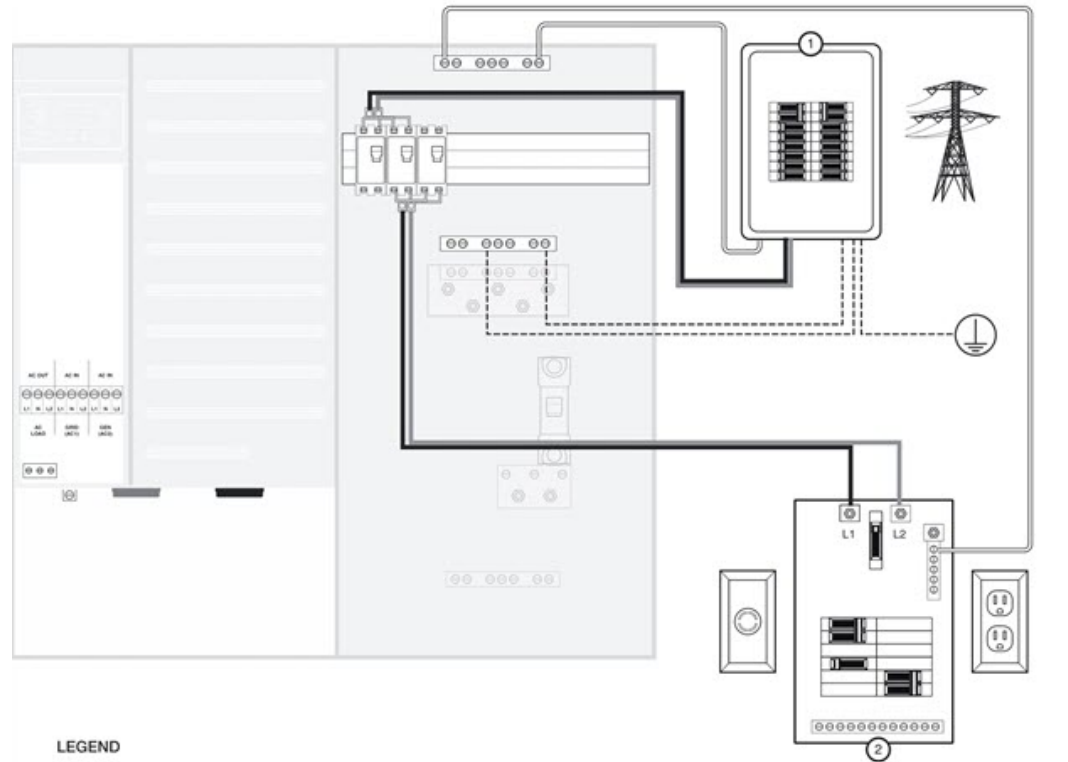
Back fed AC Power can damage equipment. Do not wire the inverter's AC output port directly to the utility line or generator output.

**Failure to follow these instructions can result in equipment damage.**

### To connect the Power Distribution Panel (PDP) to the Inverter Load Sub-Panel and Utility Grid:

1. Connect L1 (from the L1 output jumper) and L2 (from the L2 output jumper), Neutral, and Ground to your inverter load sub-panel.
2. Connect the ground wire between the PDP and the main AC Panel (utility grid).
3. Connect Neutral from the PDP to the main AC panel (utility grid).
4. Connect L1 and L2 from the input side of the 60 A, 120/240 VAC, two-pole, Type QOU AC1 breaker (L1 and L2 jumpers) to the main AC panel (utility grid).

Figure 37 Wiring the PDP to the Inverter Load Sub-Panel or Utility Grid



**LEGEND**

- 1. Main utility panel
- 2. Inverter load sub-panel
- Grounding wire.
- ==== Neutral.
- Hot L1, L2.

Actual wiring requirements may vary.  
 Cable routing may vary. See sections on Knockout Selection and Communications Network Preparation.  
 See section on Torque Requirements for torque values.

## Basic Functional Test – Single Inverter

Complete the following steps to perform a basic functional test of the Conext XW Pro. If any test fails, refer to the Troubleshooting section in the Owner's Guide for assistance.

### Confirming All Connections

After the AC and DC wiring have been installed and connected, check that all connections are correct and secure, and re-secure the AC access panel.

#### **DANGER**

##### **HAZARD OF ELECTRIC SHOCK, EXPLOSION, ARC FLASH, AND FIRE**

- Apply appropriate personal protective equipment (PPE) and follow safe electrical work practices. See NFPA 70E or CSA Z462.
- This equipment must only be installed and serviced by qualified electrical personnel.
- Never operate energized with covers removed
- Energized from multiple sources. Before removing covers identify all sources, de-energize, lock-out, and tag-out and wait 2 minutes for circuits to discharge
- Always use a properly rated voltage sensing device to confirm all circuits are de-energized.

**Failure to follow these instructions will result in death or serious injury.**

#### **DANGER**

##### **HAZARD OF ELECTRIC SHOCK, EXPLOSION, ARC FLASH, AND FIRE**

- Remove watches, rings, or other metal objects.
- This equipment must only be installed and serviced by qualified electrical personnel.
- Keep sparks and flames away from the batteries.
- Use tools with insulated handles.
- Wear protective glasses, gloves and boots.
- Do not lay tools or other metal parts on top of batteries.

**Failure to follow these instructions will result in death or serious injury.**

#### **DANGER**

##### **HAZARD OF ELECTRIC SHOCK, EXPLOSION, ARC FLASH, AND FIRE**

- Battery Circuit Breakers must be installed according to the specifications and requirements defined by Schneider Electric.
- Servicing of batteries must only be performed by qualified personnel knowledgeable of batteries and the required precautions. Keep unqualified personnel away from batteries.
- Disconnect the charging source prior to connecting or disconnecting battery terminals.

**Failure to follow these instructions will result in death or serious injury.**

## Applying DC Power to the Inverter

### NOTICE

#### DC REVERSE POLARITY

Before making the final DC connection or closing the DC breaker or disconnect, check cable polarity at both the battery and the inverter/charger. Positive (+) must be connected to positive (+). Negative (–) must be connected to negative (–).

**Failure to follow these instructions can result in equipment damage.**

#### To apply DC power to the inverter:

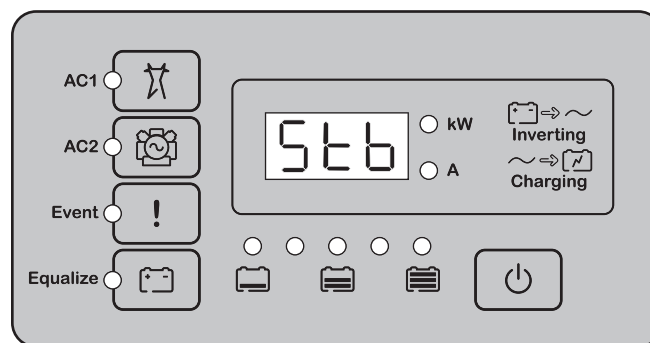
1. Before applying DC power to the inverter, measure the voltage and check polarity at all connections. (Measure at the battery side of the disconnect or breaker.)

**Note:** Voltage should be between 40 to 64 volts for a 48-volt system. If the DC voltage is low, the battery bank must be charged externally. Charge the battery bank, and then restart the functional test.

If the DC voltage is lower than the Low Battery Cut Out (LBCO) setting (44 volts for a 48-volt system) a DC Under Voltage Fault (F48) will be triggered. If the DC voltage is lower than the default LBCO voltage, lower the LBCO setting accordingly.

2. Apply battery (DC) power to the inverter by closing the battery bank DC disconnect. The inverter will power up in standby mode, and the inverter information panel will display Stb(standby), as shown in *Removing the AC Access Panel and PDP Internal Faceplates*.

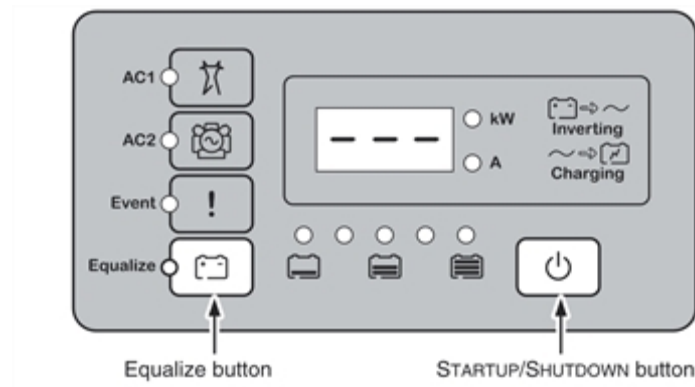
Figure 38 Power-up display



## Enabling the Inverter

Invert mode is enabled by default, and the Conext XW Pro should begin inverting upon transitioning from standby mode. If invert mode is disabled, the inverter information panel will display "—" once out of standby mode, as shown in *Removing the AC Access Panel and PDP Internal Faceplates*. If the Conext XW Pro powers up in standby mode, press the STARTUP/SHUTDOWN button momentarily to change the mode from standby to operating.

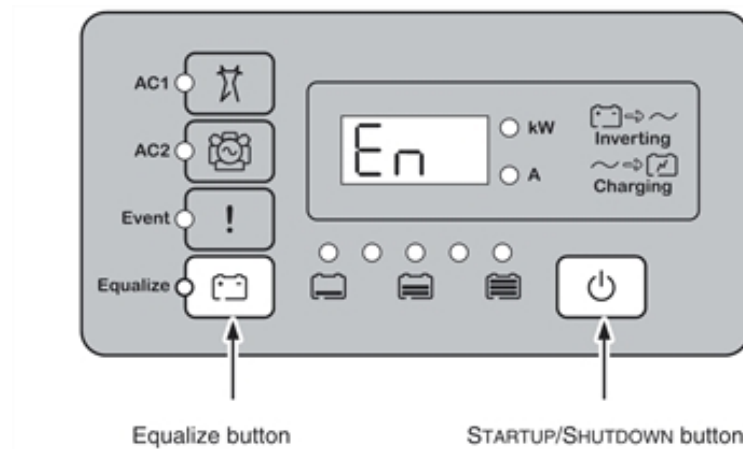
Figure 39 Disabled mode



**To enable the inverter:**

- On the inverter information panel, simultaneously press the STARTUP/SHUTDOWN button and the Equalize button. The Conext XW Pro is now enabled, and En (enabled) is briefly displayed on the inverter information panel, as shown in *Removing the AC Access Panel and PDP Internal Faceplates*.

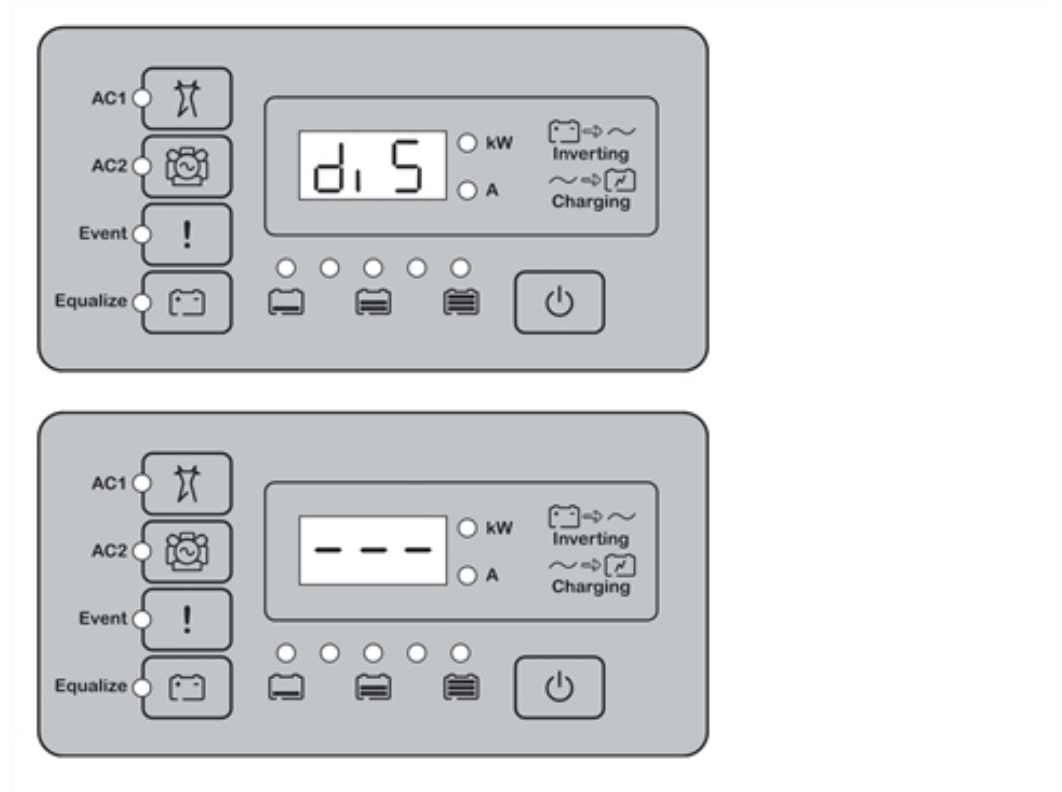
Figure 40 Enabled mode



**To disable the inverter:**

1. On the inverter information panel, simultaneously press the STARTUP/SHUTDOWN button and the Equalize button. The Conext XW Pro is now disabled, and diS (disabled) is briefly displayed on the inverter information panel, followed by "---" (as shown in *Removing the AC Access Panel and PDP Internal Faceplates*).

Figure 41 Transition to disabled mode



2. Monitor the invert (green kW) LED to confirm which mode the inverter is in:
  - a. **kW LED OFF** – Invert mode is disabled. The inverter/charger is not powering the AC loads. However, if good AC is present, it is passed through to the loads.
  - b. **Sch displayed on the inverter information panel** – The inverter/charger is in *search* mode and is looking for an AC load greater than the **Search Watts** setting (default = 25 watts). The display shows Sch (Search) when this mode has been enabled.
  - c. **LED ON** – The inverter/charger is on. The inverter is operating and is able to provide power to the AC loads. This is the default mode on initial power-up once the unit is taken out of standby mode.

If the inverter is not operating or the inverter LED (kW) does not turn on, check all connections. Check the inverter's DC voltage and polarity on the positive (+) and negative(-) terminals. Check the Fault LED. If the fault LED is on, check for a fault code on the information panel. Correct the reported fault and clear the fault by acknowledging it. If the DC voltage is low, then the battery bank needs to be charged externally. Charge the battery bank and restart the functional test.

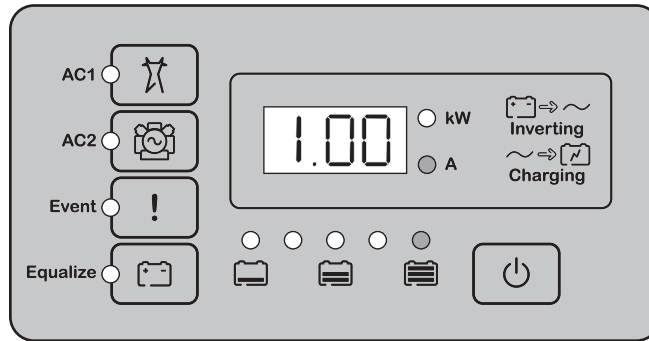
## AC Voltage Check

**Note:** This test requires the use of a voltmeter.

### To perform an AC voltage check:

1. With the inverter on (green kW LED is on and steady), verify the AC voltage at AC Loads block terminal L1-Load to N-Load.
2. Verify that neutral is bonded to ground in the system by measuring the hot and neutral voltages relative to ground. Neutral-to-ground should equal zero (0) volts.
3. After confirming the correct AC voltage, turn on your AC output breaker and place a load on the inverter (plug in a light or other load to an outlet the inverter is powering).
4. Confirm that the AC load that was just turned on is working properly.

Figure 42 Checking AC Voltage

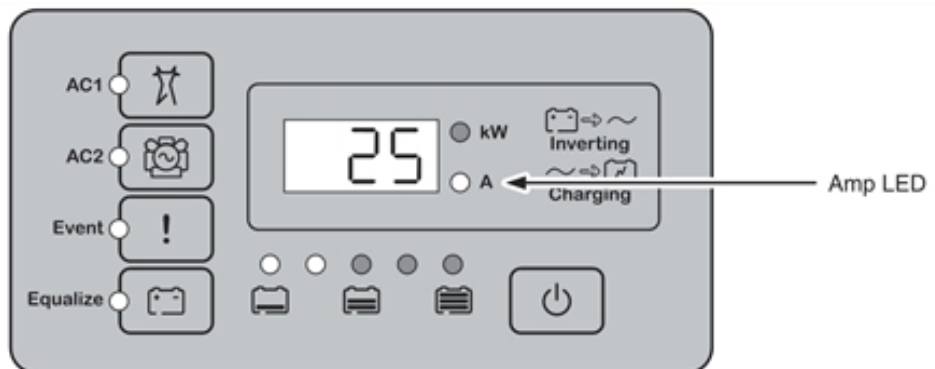


## Confirming Battery Charger Operation

### To confirm battery charger operation:

1. Apply AC from grid or generator. LEDs will blink while the power source is qualified.
2. Check LEDs (AC1 or AC2) on the front panel. One of them must be ON for the unit to charge.
3. Check the amp (A) LED. If the A LED is ON, the unit is charging and the battery current is displayed on the inverter information panel.

Figure 43 Checking Charging Operation

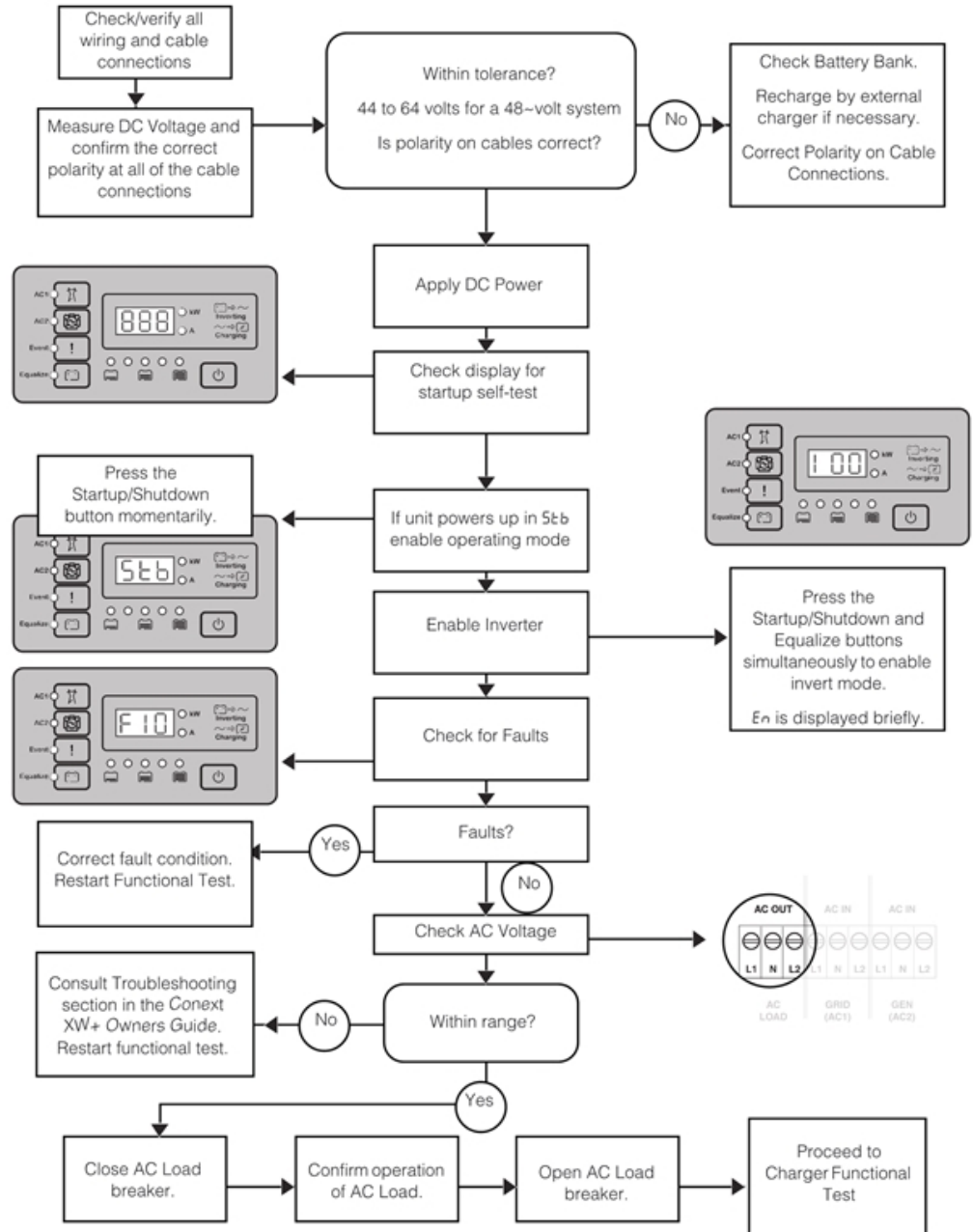




**Note:** Unless the inverter/charger settings have been changed, the inverter will charge as if it has a large (> 440 Ah) flooded battery bank (factory default setting). In newly installed systems, adjust the battery charging set points to match the batteries as installed.

This completes the functional test. If any of the internal set points need to be adjusted on the Conext XW Pro, consult the configuration chapter of the Owner's Guide.

Figure 44 Functional Test for Single Inverter Systems



## Conext XW Pro Inverter/Charger Grounding

### **WARNING**

#### **UNGROUNDING EQUIPMENT**

Equipment ground terminals must be reliably connected to ground by appropriately sized grounding conductors. All installations must comply with national and local codes. Consult local and national codes for specific grounding and bonding requirements.

**Failure to follow these instructions can result in death, serious injury, or equipment damage.**

The Conext XW Pro is provided with ground terminals that must be reliably connected to ground (protective earth) by appropriately sized equipment grounding conductors. System grounding for the AC and DC systems must be done according to all applicable NEC and local installation codes.

For more information about system grounding, see *Removing the AC Access Panel and PDP Internal Faceplates on page 43* and *Removing the AC Access Panel and PDP Internal Faceplates on page 43*.

## Wiring the Conext XW Pro Inverter/Charger without a PDP

### **DANGER**

#### **HAZARD OF ELECTRIC SHOCK, EXPLOSION, ARC FLASH, AND FIRE**

- Apply appropriate personal protective equipment (PPE) and follow safe electrical work practices. See NFPA 70E or CSA Z462.
- This equipment must only be installed and serviced by qualified electrical personnel.
- Never operate energized with covers removed
- Energized from multiple sources. Before removing covers identify all sources, de-energize, lock-out, and tag-out and wait 2 minutes for circuits to discharge
- Always use a properly rated voltage sensing device to confirm all circuits are de-energized.

**Failure to follow these instructions will result in death or serious injury.**

**⚡ ⚠ DANGER****HAZARD OF ELECTRIC SHOCK, EXPLOSION, ARC FLASH, AND FIRE**

- Remove watches, rings, or other metal objects.
- This equipment must only be installed and serviced by qualified electrical personnel.
- Keep sparks and flames away from the batteries.
- Use tools with insulated handles.
- Wear protective glasses, gloves and boots.
- Do not lay tools or other metal parts on top of batteries.

**Failure to follow these instructions will result in death or serious injury.**

**⚡ ⚠ DANGER****HAZARD OF ELECTRIC SHOCK, EXPLOSION, ARC FLASH, AND FIRE**

- Battery Circuit Breakers must be installed according to the specifications and requirements defined by Schneider Electric.
- Servicing of batteries must only be performed by qualified personnel knowledgeable of batteries and the required precautions. Keep unqualified personnel away from batteries.
- Disconnect the charging source prior to connecting or disconnecting battery terminals.

**Failure to follow these instructions will result in death or serious injury.**

This section provides illustrations for wiring the AC and DC connections for a Conext XW Pro without a Power Distribution Panel (PDP).

## Pre-Installation Steps

Depending on your installation, you will need to perform some or all of some the following pre-installation steps:

1. Prepare the battery bank. See *Pre-Installation on page 27*.
2. Wall-mount the Conext XW Pros. See *Pre-Installation on page 27*.
3. Install Related Documents as needed. See *Pre-Installation on page 27*.
4. Install AC sync and Xanbus cable(s) as needed. See *The Xanbus Network on page 83*.
5. Remove knockouts on the Conext XW Pro as needed to accommodate the wiring. See *Pre-Installation on page 27* for more information about knockouts.

## Feed-in Protection Requirements

### **NOTICE**

#### **OVERLOADING THE DISTRIBUTION PANEL**

The amount of power that can be fed into a distribution panel and the means and location for feed-in, must be in accordance with NEC 2008 article 690.64 or the current requirements of the local electrical code.

**Failure to follow these instructions can result in equipment damage.**

## Conext XW Pro Inverter/Charger Grounding

### **⚠ WARNING**

#### **UNGROUNDING EQUIPMENT**

Equipment ground terminals must be reliably connected to ground by appropriately sized grounding conductors. All installations must comply with national and local codes. Consult local and national codes for specific grounding and bonding requirements.

**Failure to follow these instructions can result in death, serious injury, or equipment damage.**

The Conext XW Pro is provided with ground terminals that must be reliably connected to ground (protective earth) by appropriately sized equipment grounding conductors. System grounding for the AC and DC systems must be done according to all applicable NEC and local installation codes.

For more information about system grounding, see *Removing the AC Access Panel and PDP Internal Faceplates on page 43* and *Removing the AC Access Panel and PDP Internal Faceplates on page 43*.

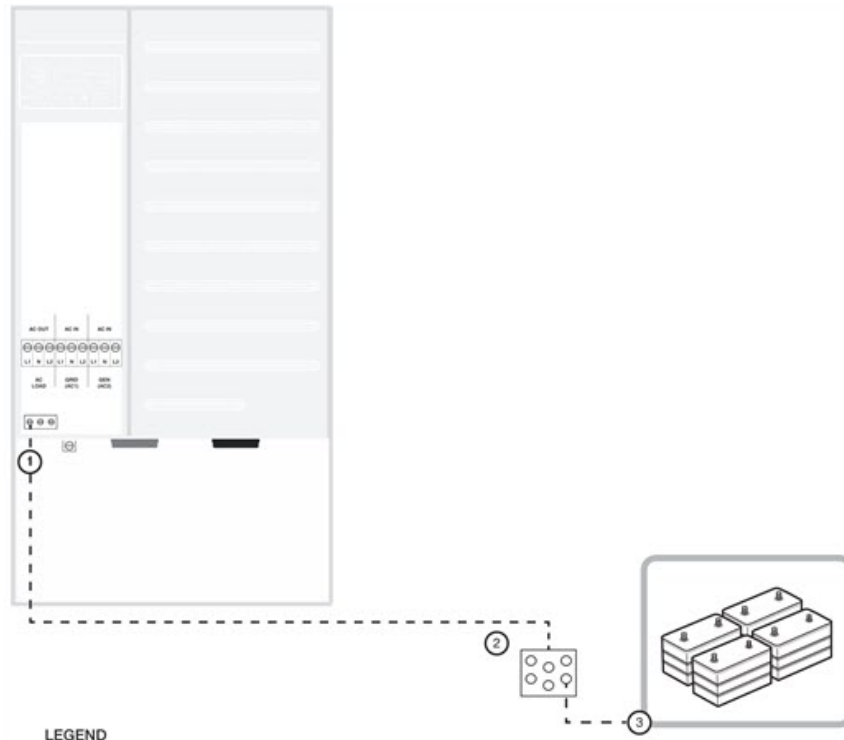
## Grounding the DC System

To connect the Conext XW Pro to the DC grounding system, use the ground lug at the bottom of the Conext XW Pro chassis (see *Conext XW Pro Features on page 20*). The terminal accepts wires from #14 AWG (1.63 mm) to #2AWG (6.54 mm).

System grounding for the DC system, which typically involves bonding (connecting) the battery negative circuit to ground, is dependent on the system configuration.

**Note:** If a grounded DC system is required, ensure that the system bonding is done in one location only, and that all conductors and connections comply with all applicable NEC and local installation codes.

Figure 45 Grounding the DC System (No PDP)



**LEGEND**

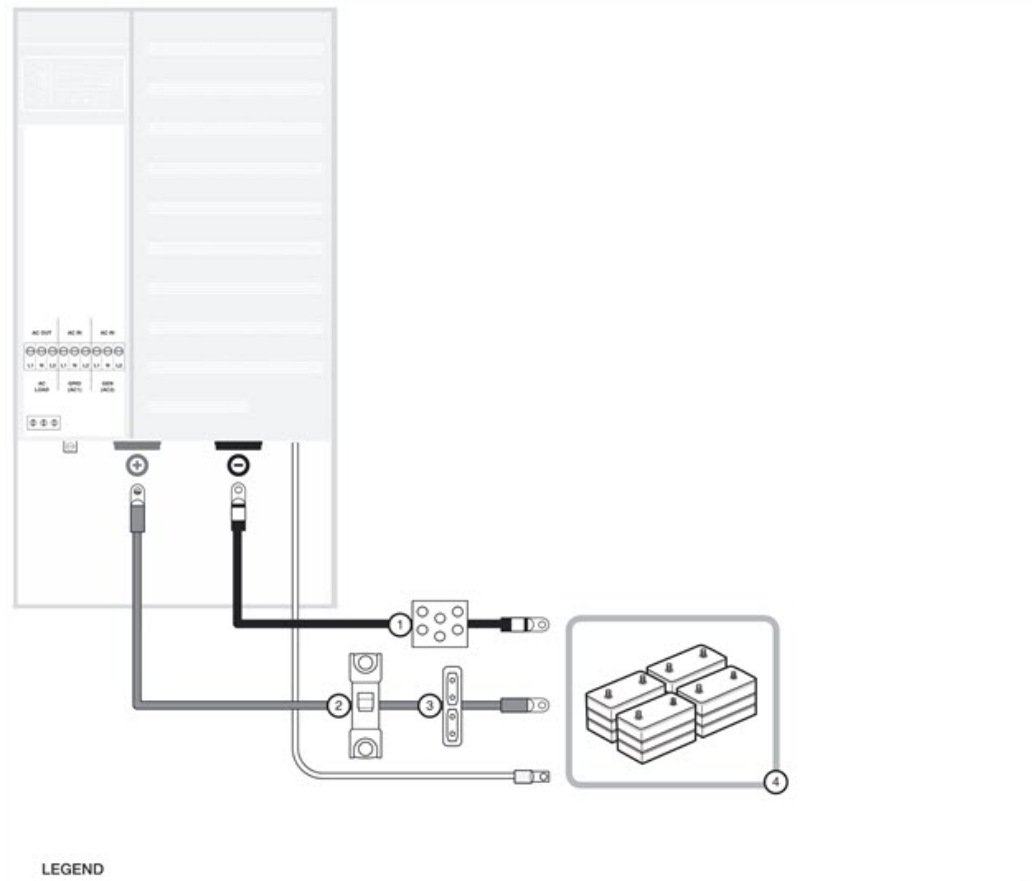
- 1. AC Ground bar
- 2. Negative ground/bus
- 3. Vented battery enclosure

Actual wiring requirements may vary.

Cable routing may vary. See sections on Knockout Selection and Communications Network Preparation.




See section on Torque Requirements for torque values.

Figure 46 DC Connections to a Single Inverter (No PDP)



**LEGEND**

- 1. Negative ground/bus
- 2. Circuit breaker/DC disconnect
- 3. Fuse block (optional)
- 4. Vented battery enclosure

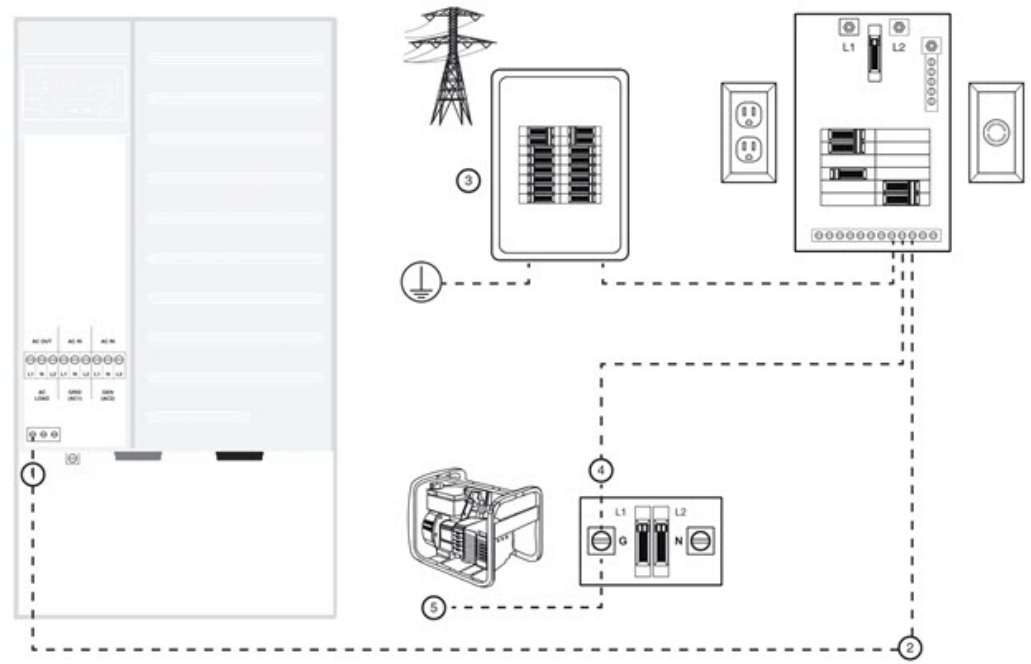
-  BTS cable
-  Positive (+)  
Battery cable
-  Negative (-)  
Battery cable

Actual wiring requirements may vary.

Cable routing may vary. See sections on Knockout Selection and Communications Network Preparation.

See section on Torque Requirements for torque values.

Figure 47 Grounding the AC System (No PDP)



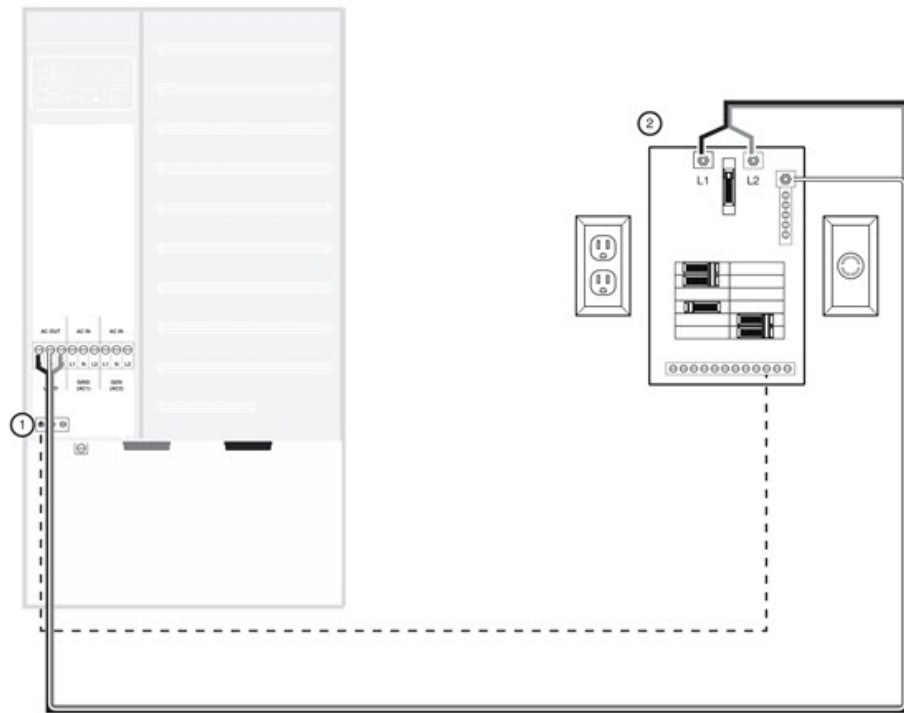
**LEGEND**

- 1. To AC ground bar
- 2. To inverter load sub-panel
- 3. To main utility panel

- 4. Generator disconnect  
Note: Depending on the location of the generator and local code requirements, the generator disconnect may be located in the power distribution panel.
- 5. To AC generator

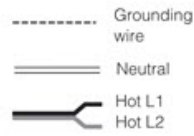
Actual wiring requirements may vary.  
Cable routing may vary. See sections on Knockout Selection and Communications Network Preparation.  
See section on Torque Requirements for torque values.

Figure 48 AC Output Wiring to the Inverter Load Sub-Panel (No PDP)



**LEGEND**

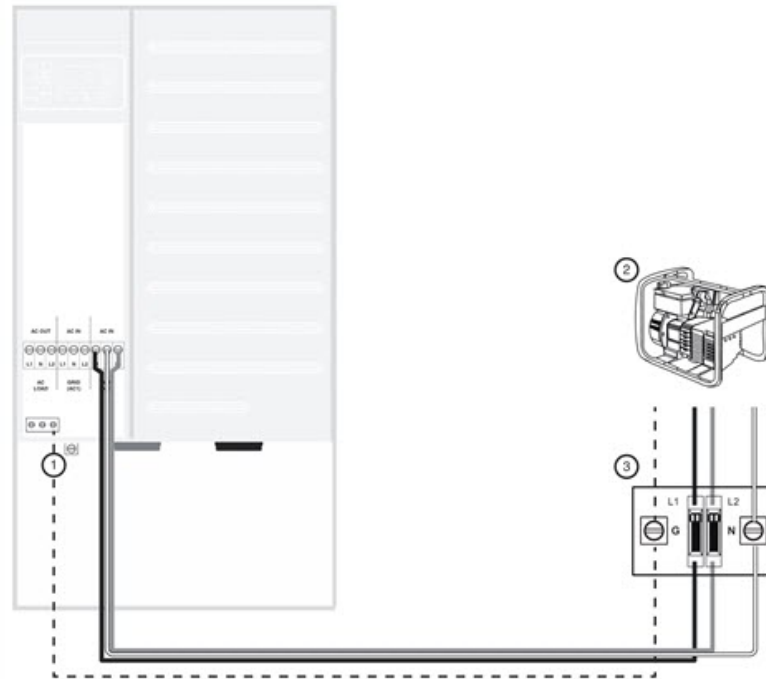
- 1. AC ground bar
- 2. Inverter load sub-panel



Actual wiring requirements may vary.  
Cable routing may vary. See sections on Knockout Selection and Communications Network Preparation.  
See section on Torque Requirements for torque values.

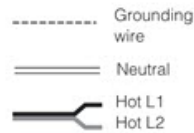


Figure 49 Generator Wiring directly to the Inverter (No PDP)



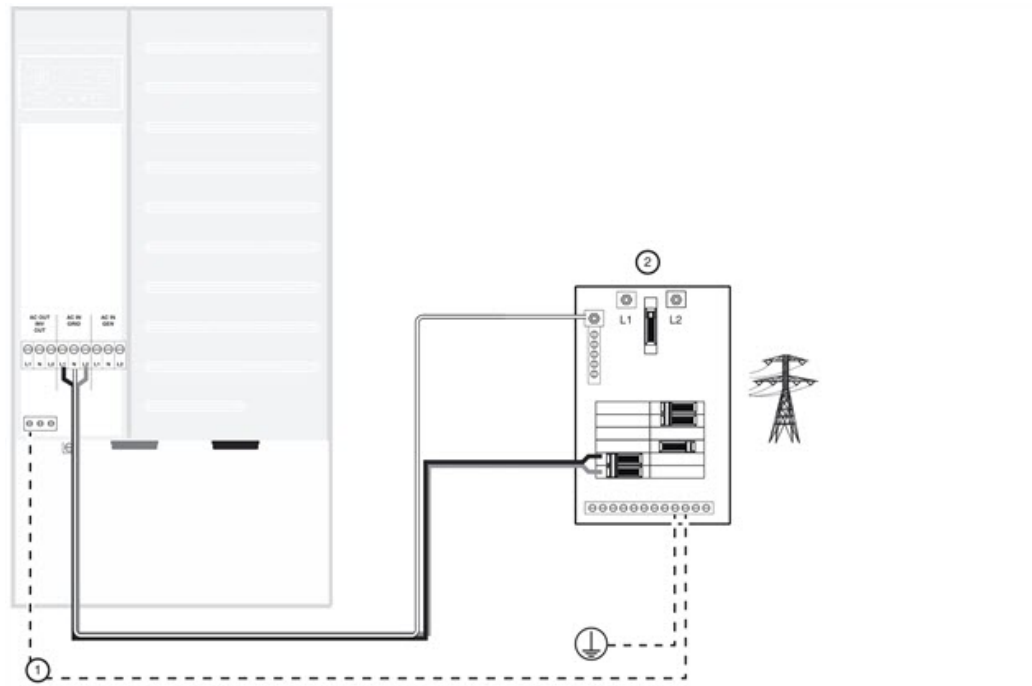
LEGEND

- 1. AC ground bar
- 2. Generator
- 3. Generator disconnect



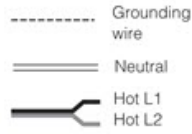
Actual wiring requirements may vary.  
 Cable routing may vary. See sections on Knockout Selection and Communications Network Preparation.  
 See section on Torque Requirements for torque values.

Figure 50 Utility Wiring to the Inverter Input (No PDP)



LEGEND

- 1. AC ground bar
- 2. Main utility panel



Actual wiring requirements may vary.  
Cable routing may vary. See sections on Knockout Selection and Communications Network Preparation.  
See section on Torque Requirements for torque values.

## 4 Communication

### What's in This Chapter?

<b>The Xanbus Network</b> .....	<b>83</b>
Network Components .....	83
<b>Installing the Network</b> .....	<b>86</b>
Before You Begin the Installation .....	86
Installation Tools and Materials .....	86
Installing Xanbus cables .....	86
Guidelines for Routing the Xanbus Cables .....	88

# The Xanbus Network

A Xanbus network is a collection of Xanbus enabled devices that perform individual functions, but also communicate and interact with other devices on the network. The network capability of the Conext XW Pro provides a solution that simplifies and automates the installation, configuration, control, monitoring, and integration of devices.

## Network Components

**NOTICE**

**SHORT CIRCUIT OF NETWORK COMPONENTS**

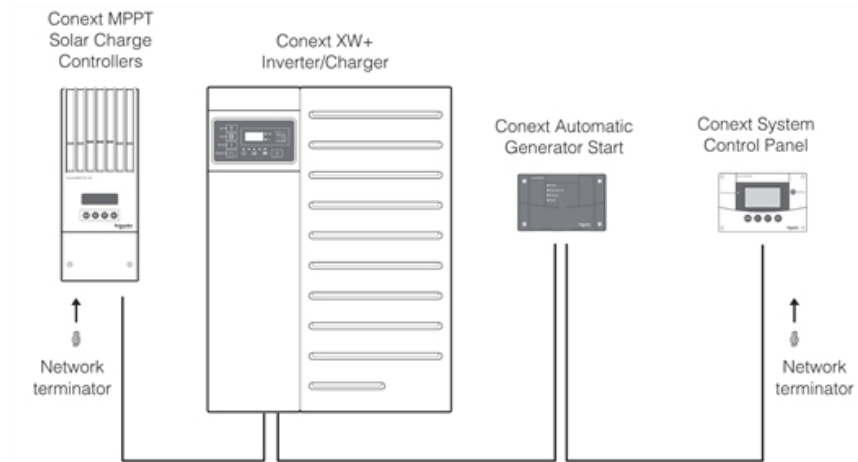
- **This network is not an ethernet system.** Only connect Xanbus-enabled devices to other Xanbus-enabled devices. Do not attempt to connect Xanbus-enabled devices to other networks or systems.
- Ethernet crossover cables are not compatible with the Xanbus system. Use Category 5 (CAT 5 or CAT 5e) cables to connect Xanbus-enabled devices.
- Do not install network terminators in an AC Sync port.

**Failure to follow these instructions can result in equipment damage.**

A Xanbus network consists of three elements: Xanbus-enabled devices, Xanbus power supply, and Xanbus cables.

Each device is integrated into the network using cables, network connectors, and terminators. An example of a network system is shown in *The Xanbus Network*.

*Figure 51 Xanbus Network System (Example)*



## Power Distribution Panel (without AC Breakers)-enabled devices

**A Xanbus-enabled device is any product that works on a Xanbus network. Below are some examples of Xanbus-enabled devices:**

- Conext SCP
- Conext XW Pro

- Conext AGS
- Conext Battery Monitor
- Conext MPPT solar charge controller MPPT 60 150
- Conext MPPT solar charge controller MPPT 80 600

Due to network traffic, the maximum number of Conext XW Pro units in a single Xanbus network should not exceed twelve. The maximum number of Conext MPPT Solar Charge Controllers in a single Xanbus network should not exceed twelve.

The combined maximum number of Conext XW Pro units and Conext MPPT Solar Charge Controllers should not exceed twelve.

## Xanbus power supply

Xanbus-enabled devices are either power-supplying or power-consuming. The Xanbus network needs at least one device with a power supply sufficient to run the entire network.

**Note:** The total network current supplied by the power-sourcing devices must be equal to or greater than the total current drawn by the power-consuming devices. The power supply must be capable of providing 15 VDC/200 mA to each device.

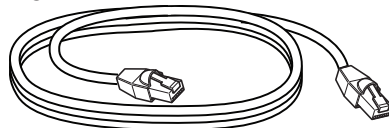
For example, in a system with a Conext XW Pro, Conext SCP, and Conext AGS, the Conext XW Pro is a power-supplying device capable of providing 800 mA at 15 VDC while the two other devices each consume a maximum of 200 mA for a total maximum consumption of 400 mA. In this example, the network is properly configured from a power perspective because the power source is capable of providing more current than is needed: 800 mA > 400 mA.

**Note:** See the specifications for each Xanbus-enabled device to determine how much power each device consumes or supplies.

## Xanbus cables

Each Xanbus-enabled device is connected by a Category 5 (CAT 5 or CAT 5e) cable, a standard cable available from the manufacturer or any computer supply store. The cable consists of eight conductors in four twisted pairs with an RJ45 modular connector wired to the T568A standard. The minimum cable length should be 6 ft. (1.8 m).

*Figure 52 Xanbus Cable*



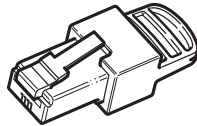
## Network terminators

The Xanbus network must be properly terminated at each end to ensure the communication signal quality on the network.

**Note:** If the network is not properly terminated, signal quality is degraded and performance on the network is reduced. Permanent configuration without terminators is not supported.

The Conext XW Pro and other Xanbus-enabled devices ship with one network terminator. Depending on your network layout, this terminator may need to be removed from the Conext XW Pro Inverter/Charger and inserted into another device elsewhere in the network.

*Figure 53 Network terminator*



## Installing the Network

**Note:** Installing and replacing Xanbus-enabled devices in an existing system must be performed with the Conext XW Pro in standby mode. For more information about standby mode, see the Owner's Guide.

### Before You Begin the Installation

- Read the entire section before installing the network. It is important to plan the installation from beginning to end.
- Assemble all the tools and materials required for the installation.

### Installation Tools and Materials

#### Tools

A Phillips head screwdriver, appropriately sized is required to install the Xanbus cables.

#### Materials

The following materials may be required to complete the installation.

- CAT 5 or CAT 5e cables (available from computer supply stores)
- Terminators

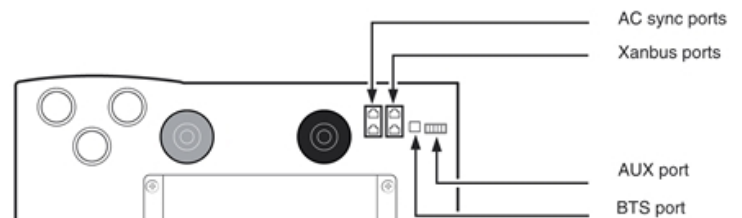
**Note:** Mount cables and network connectors in a dry location.

### Installing Xanbus cables

Install these cables, routing them through the Conduit Box raceway, prior to making the AC and DC wiring connections.

**Note:** If you are installing a Xanbus-enabled device on an existing Xanbus system, put the system in standby mode using the **System Settings** menu on the Conext SCP.

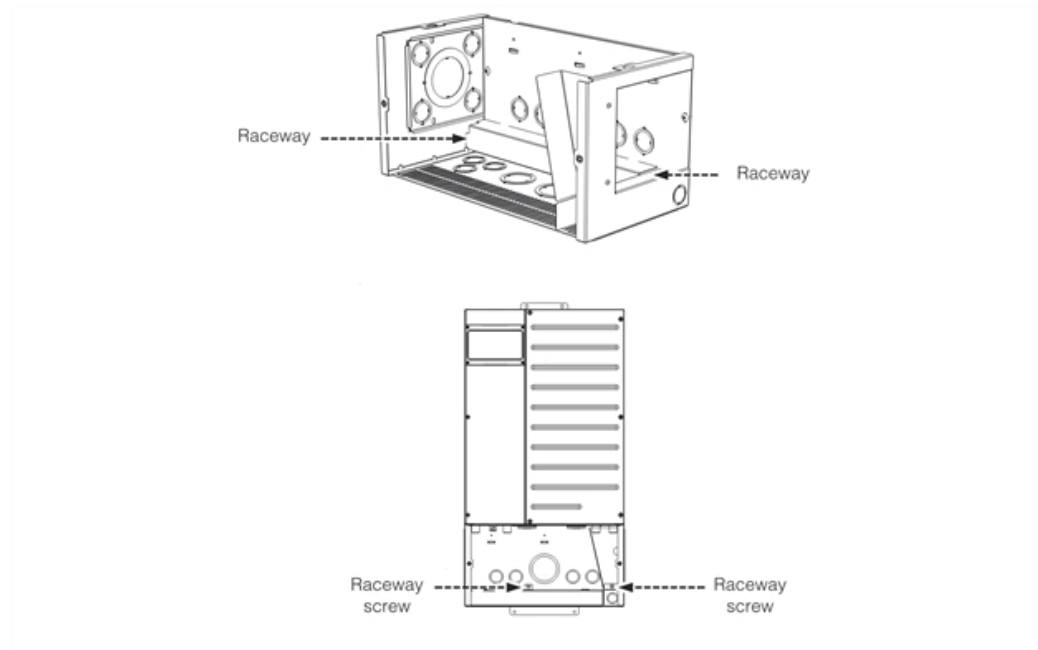
Figure 54 Conext XW Pro communication ports



#### To install the Xanbus cables:

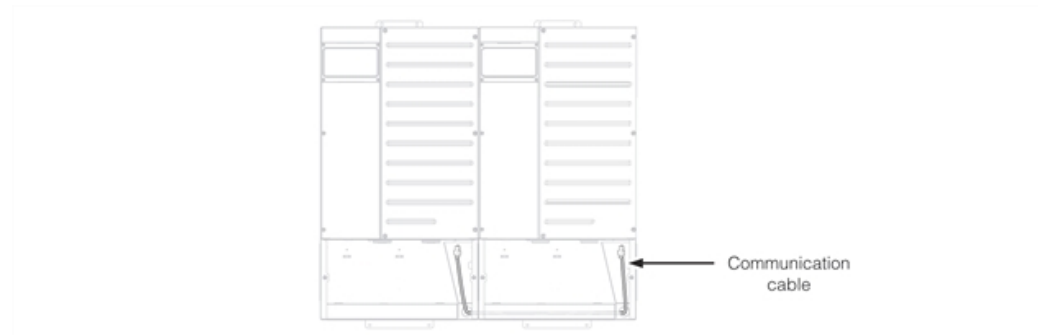
1. Remove the two raceways for the communication cabling by removing the screw holding each raceway in place, as shown in *The Xanbus Network*.

Figure 55 Conduit Box raceways



2. Route the cable as shown in *The Xanbus Network*. Route any additional communication cables through the raceways. Replace the wiring raceways, ensuring not to pinch the cables. Secure the raceways to the Conduit Box with the screw that was removed earlier.

Figure 56 Installing the Xanbus cables





## Guidelines for Routing the Xanbus Cables

### **WARNING**

#### **XANBUS SHOCK HAZARD**

Xanbus cables in contact with DC or AC power can transmit an electric shock. Do not route the Xanbus cables in the same conduit or panel as the AC and DC power cabling.

**Failure to follow these instructions can result in death, serious injury, or equipment damage.**

To ensure maximum performance of your network, follow these guidelines when routing the Xanbus cables.

- Route the cables away from sharp edges that might damage the insulation. Avoid sharp bends in the cable—no less than a 4-inch (100 mm) radius.
- Allow at least 2 ¼ inches (57 mm) of space behind the wall to accommodate the depth of the unit and allow room for the cables to bend.
- Allow for some slack in the cable tension.
- Keep the alignment of wire pairs inside the sheath as straight as possible.
- Allow separation between data and power cables (data cables should only cross over a power cable at right angles).
- Avoid using metal cable staples. Use appropriate hardware fasteners to avoid damage to the cable.
- Support horizontal cables using J hooks or cable trays.

The total length of the network, including all connected Xanbus-enabled devices and the Conext XW Pro, cannot exceed 130 feet (40 m).



## 5 Access Installation

### What's in This Chapter?

<b>Conext SCP Installation</b> .....	<b>91</b>
Installing the SCP via the Xanbus Network .....	91
Replacing the Inverter Information Panel with the SCP .....	92
Verifying the Installation .....	95

## Conext SCP Installation


The Conext XW Pro can be controlled remotely by connecting a Conext SCP.

The SCP allows access to programming features of the Conext XW Pro and allows the system to be modified to specific installation requirements.

The SCP can be connected to the Conext XW Pro through one of the following two methods:

- via the Xanbus network or
- by replacing the inverter information panel with the SCP (see next section).

### Installing the SCP via the Xanbus Network

 **WARNING**

**IGNITION AND FIRE HAZARD**

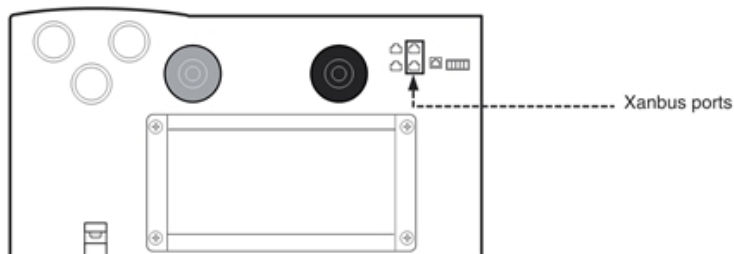
This equipment is not ignition protected. To prevent fire or explosion, do not install this product in locations that require ignition-protected equipment. This includes any confined space containing vented batteries, or flammable chemicals such as, natural gas (NG), liquid petroleum gas (LPG) or gasoline (Benzine/Petrol).

- Do not install in a confined space with machinery powered by flammable chemicals, or storage tanks, fittings, or other connections between components of fuel or flammable chemical systems.
- Do not install the inverter near readily flammable materials such as cloth, paper, straw, or plastic sheeting. Keep flammable materials a minimum distance of 600 cm (24 in.) from the top surface and 30 cm (12 in.) from either side surface and the front of the Conext XW Pro Inverter/Charger.

**Failure to follow these instructions can result in death, serious injury, or equipment damage.**

The SCP is connected to the Xanbus network via either of the two Xanbus network ports located at the bottom of the Conext XW Pro chassis (as shown in *Figure 57* ).

*Figure 57 Xanbus Port Locations*



For more information about installing a Xanbus-enabled device as part of a network system, see "*The Xanbus Network*" on page 83.

For wall-mounting and other installation instructions, see the *Conext System Control Panel Owner's Guide* (975-0298-01-01).

## Replacing the Inverter Information Panel with the SCP

To remove the inverter information panel from the Conext XW Pro chassis:

### **DANGER**

#### **HAZARD OF ELECTRIC SHOCK, EXPLOSION, ARC FLASH, AND FIRE**

- Apply appropriate personal protective equipment (PPE) and follow safe electrical work practices. See NFPA 70E or CSA Z462.
- This equipment must only be installed and serviced by qualified electrical personnel.
- Never operate energized with covers removed
- Energized from multiple sources. Before removing covers identify all sources, de-energize, lock-out, and tag-out and wait 2 minutes for circuits to discharge
- Always use a properly rated voltage sensing device to confirm all circuits are de-energized.

**Failure to follow these instructions will result in death or serious injury.**

### **DANGER**

#### **HAZARD OF ELECTRIC SHOCK, EXPLOSION, ARC FLASH, AND FIRE**

- Remove watches, rings, or other metal objects.
- This equipment must only be installed and serviced by qualified electrical personnel.
- Keep sparks and flames away from the batteries.
- Use tools with insulated handles.
- Wear protective glasses, gloves and boots.
- Do not lay tools or other metal parts on top of batteries.

**Failure to follow these instructions will result in death or serious injury.**

### **DANGER**

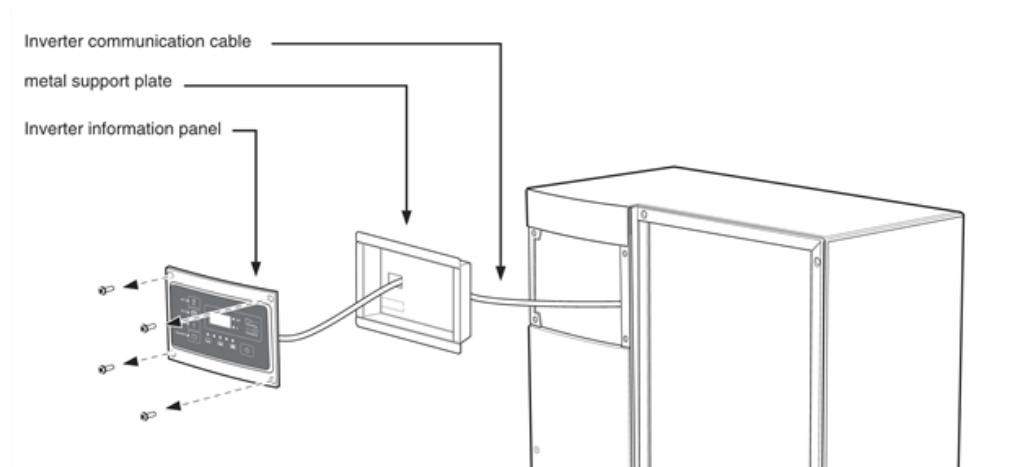
#### **HAZARD OF ELECTRIC SHOCK, EXPLOSION, ARC FLASH, AND FIRE**

- Battery Circuit Breakers must be installed according to the specifications and requirements defined by Schneider Electric.
- Servicing of batteries must only be performed by qualified personnel knowledgeable of batteries and the required precautions. Keep unqualified personnel away from batteries.
- Disconnect the charging source prior to connecting or disconnecting battery terminals.

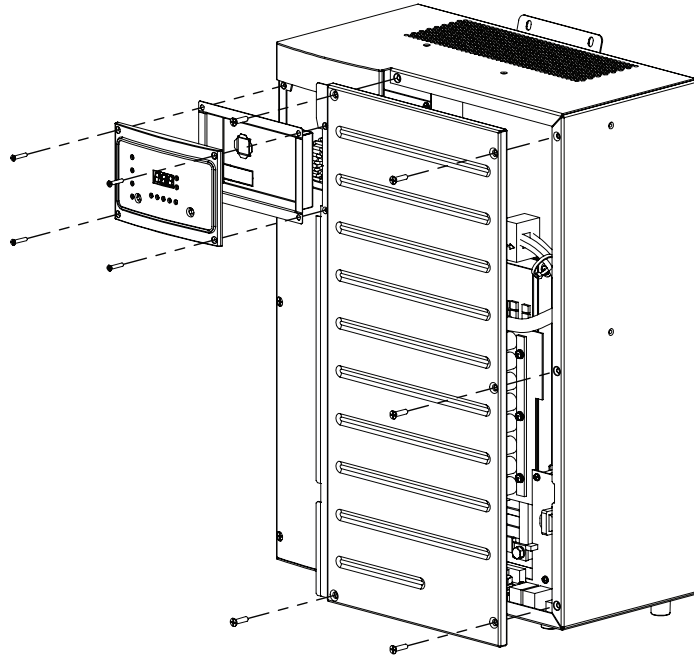
**Failure to follow these instructions will result in death or serious injury.**

1. If the AC access panel is attached to the Conext XW Pro chassis, remove it (as shown in *AC access panel removal on page 44*).
2. Remove the four screws from the inverter information panel, as shown in *Conext SCP Installation*.

*Figure 58 Inverter information panel removal*



3. Carefully remove the inverter information panel from the Conext XW Pro chassis, and detach it from the inverter communication cable.
4. Remove the metal support plate from the housing of the Conext XW Pro chassis.
5. For easier access, remove the right-side panel of the Conext XW Pro, as shown in *Figure 59*.

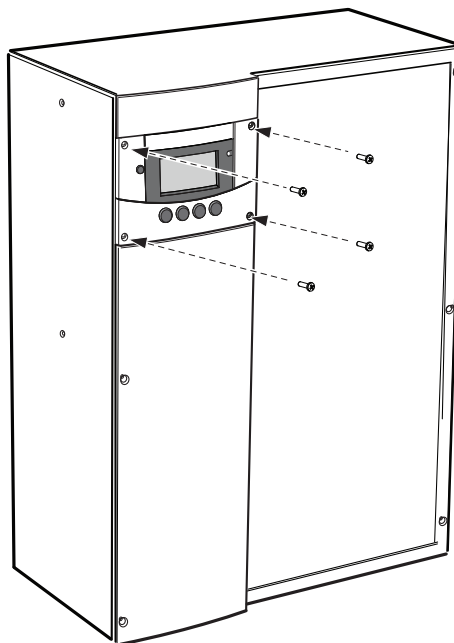
*Figure 59 Right-side panel removal*

6. Unplug the communication cable from the upper communication port

**To install the SCP into the Conext XW Pro chassis:**

1. Plug the inverter communication cable into the lower communication port.
2. Re-secure the right-side panel (if applicable).
3. Carefully place the SCP into the housing of the Conext XW Pro chassis.
4. Secure the SCP with the four screws removed from the inverter information panel.

Figure 60 Mounting plate centered on wall studs



5. When all wiring is complete, re-secure the AC access panel to the Conext XW Pro chassis. For more information, see *Removing the AC Access Panel and PDP Internal Faceplates* on page 43.

For more information about the Conext SCP, see the *Conext XW Pro Owner's Guide*.

## Verifying the Installation

If network power (from an inverter/charger) is present, the SCP backlight will illuminate and the startup screen will appear, followed by the system Home screen. For more information, see the *Conext XW Pro Owner's Guide*.



## 6 Specifications

### What's in This Chapter?

<b>Specifications</b> .....	<b>97</b>
Electrical Specifications .....	97
Conext XW Pro Overload Capability .....	98
Output Power Versus Ambient Temperature .....	99
Conext XW Pro Efficiency .....	100
<b>Mechanical Specifications</b> .....	<b>102</b>
<b>Accessories</b> .....	<b>103</b>

# Specifications

"Specifications" above provides the electrical and mechanical specifications for the Conext XW Pro.

**DISCLAIMER REGARDING STATUS DATA**

Status data reported by the Conext XW Pro are approximate values intended to provide general and non-exact information about the Conext XW Pro. Under no circumstances should this status data be used for precise evaluation of the Conext XW Pro system performance, including efficiency considerations. In systems with a single Conext XW Pro, the measurement capabilities of the inverter/charger allow for deviations of up to 5% of actual values. For systems requiring higher accuracy status reporting of ac parameters, Schneider Electric recommends the use of external monitoring equipment of appropriate and accurate calibration. for higher accuracy measurement of dc (battery) parameters, Schneider Electric recommends installing an appropriate dc battery monitor in the system.

## Electrical Specifications

**NOTE:** Specifications are subject to change without prior notice.

*Table 13 Conext XW Pro Electrical Specifications*

	<b>XW Pro 6848 NA</b>
Continuous Output Power	6,800 W
Surge Rating (Overload for 1 minute)	12,000 W
Surge Rating (Overload for 5 minutes)	11,000 W
Surge Rating (Overload for 30 minutes)	8,500 W
Surge Current (120V configuration)	104 A <sub>rms</sub> (60 s)
Surge Current (120/240V configuration)	52 A <sub>rms</sub> (60 s)
Waveform	True Sine Wave
Idle Consumption—Inverter mode, no load	28 W
Idle Consumption—Search mode	< 8 W
AC Output Voltage	L-N: 120 VAC ±3% L-L: 240 VAC ±3%
AC Input Voltage range (120V configuration), (Bypass/Charger Mode)	78–140 VAC (120 V nominal)
AC Input Voltage range (120/240V configuration), (Bypass/Charger Mode)	160–270 VAC (240 V nominal)
AC Input Breaker	60 A double-pole
AC Input Frequency Range (Bypass/Charger Mode)	52–68 Hz (default) 44–70 Hz (allowable)
AC Output Current (maximum 75% imbalance between L1-N, L2-N) in Inverter Mode (120V configuration)	L-N: 48 A

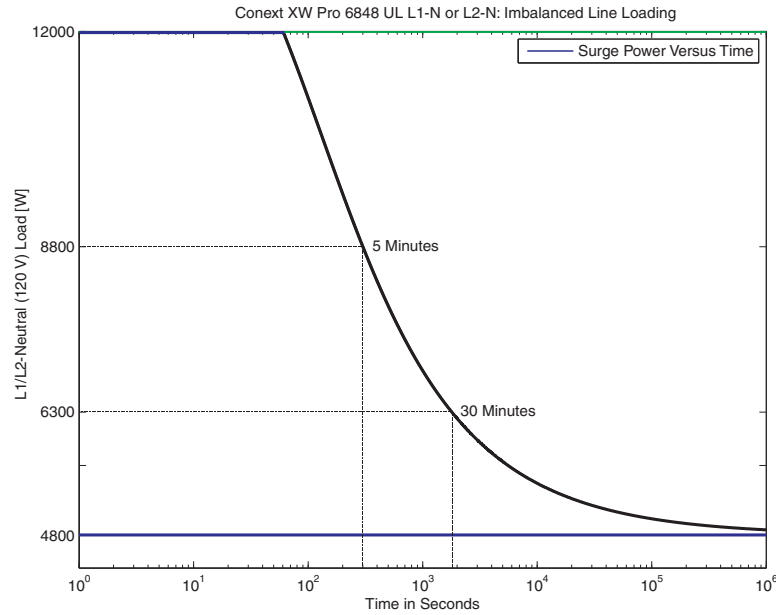
	<b>XW Pro 6848 NA</b>
AC Output Current (maximum 75% imbalance between L1-N, L2-N) in Inverter Mode (120/240V configuration)	L-L: 28 A
AC Output Breaker	60 A double-pole
AC Output Frequency	60.0 ±0.1 Hz
Total Harmonic Distortion	< 5% at rated power
Automatic Transfer Relay	60 A
Auxiliary Relay Output	0–12 VDC, maximum 250 mA DC
Peak Efficiency	95.7%
CEC Weighted Efficiency	92.5%
CEC Power Rating	
DC Input Voltage (Nominal)	48 VDC
DC Input Voltage Range	40–64 VDC
DC Current at Rated Continuous Power (Inverter Mode)	180 A
Continuous Charge Rate (Charger Mode) 120 V Configuration	120 A
Continuous Charge Rate (Charger Mode) 120/240V Configuration	140 A
Power Factor Corrected Charging	PF (0.98)
Typical Transfer Time	80 ms

## Conext XW Pro Overload Capability

Loads connected to the inverter are seldom constant, and large loads are often operated for short periods. To accommodate larger loads, the Conext XW Pro can temporarily exceed its continuous output power rating.

The graphs below illustrate approximate operation time versus load. Inverter operation time during overload is limited by both inverter internal temperature protection and by the product of AC output current and elapsed time.

Figure 61 AC Overload Capability

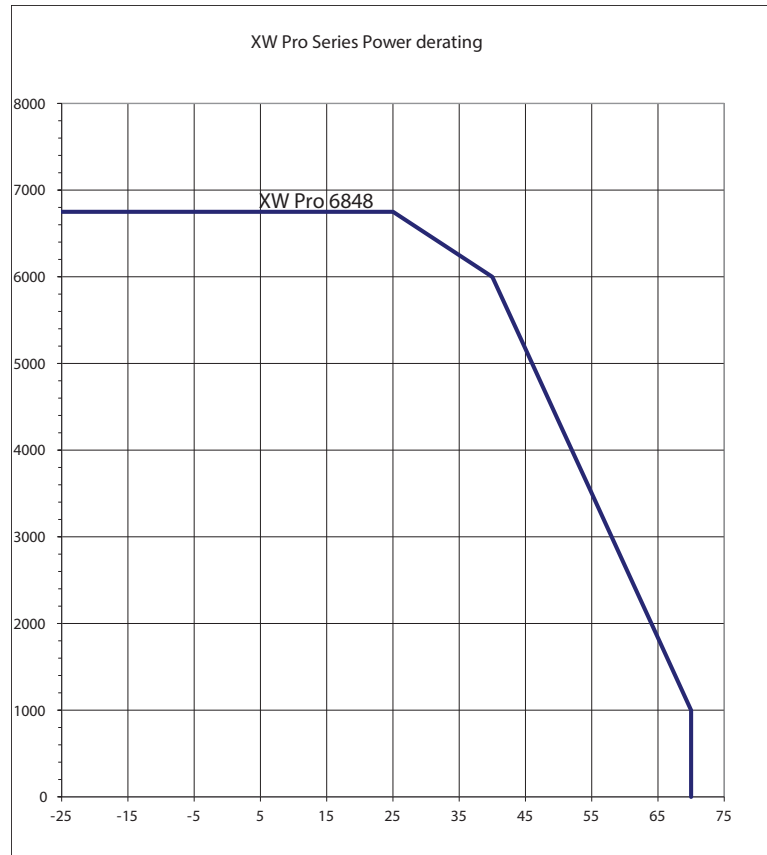


## Output Power Versus Ambient Temperature

For the Conext XW Pro 6848 model, the power can be limited by the installed DC and AC breakers. For example, at 8500 W the DC or AC breakers may disconnect before the 30 minute rating.

When the internal temperature of the Conext XW Pro exceeds a preset limit, it begins to limit output power automatically to stop maximum internal temperatures from being exceeded.

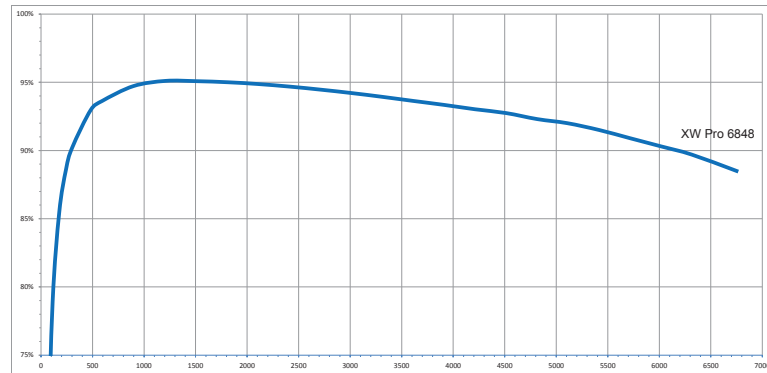
Figure 62 Output Power Versus Ambient Temperature



### Conext XW Pro Efficiency

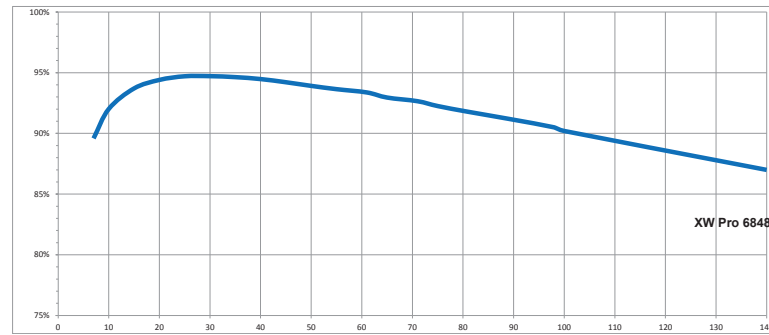
#### Inverting Efficiency (Typical)

Figure 63 Inverting Efficiency (Typical)



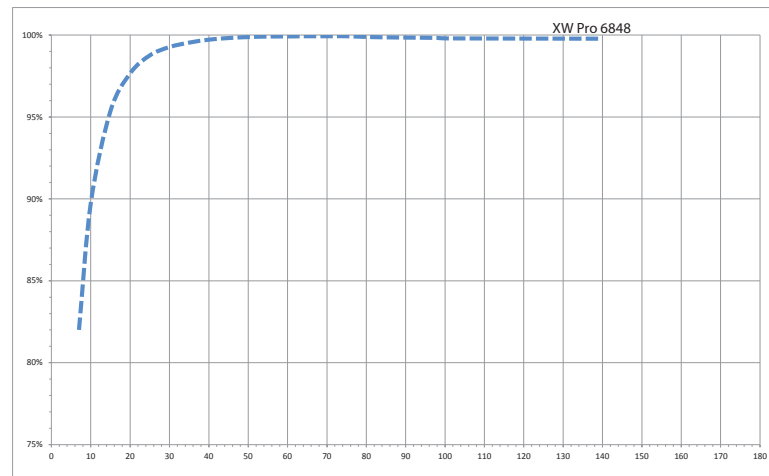
### Charging Efficiency (Typical)

Figure 64 Charging Efficiency (Typical)



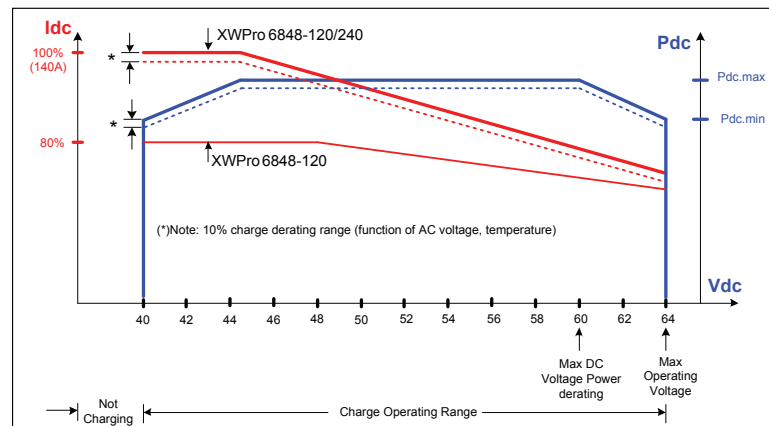
### Charging Efficiency Power Factor

Figure 65 Charging Efficiency (Power Factor)



### Maximum Charging Current

Figure 66 Charging Current



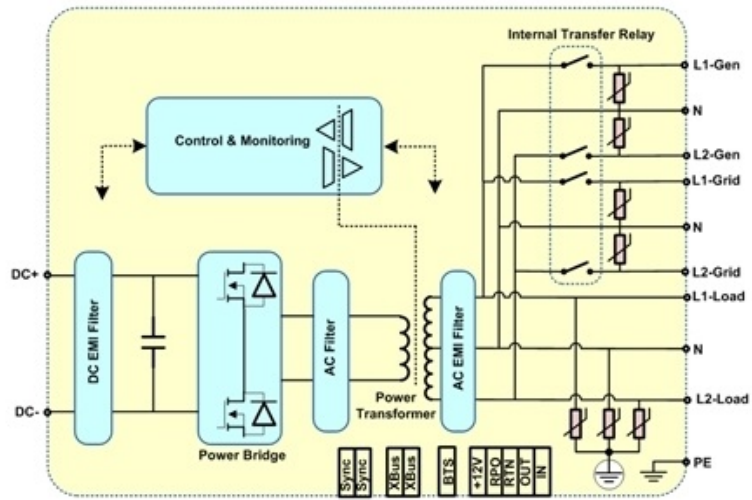
## Mechanical Specifications

**NOTE:** Specifications are subject to change without prior notice.

*Table 14 Conext XW Pro Mechanical Specifications*

<b>Model</b>	<b>XW Pro 6848 NA</b>
Supported Battery Types	Flooded (default), Gel, AGM, Lithium Ion, Custom
Battery bank size	440–10000 Ah
Non-Volatile Memory	Yes
Inverter Information Panel	Status LEDs indicate AC In status, faults/warnings, equalize mode, battery level. 3-character display indicates output power or charge current, fault/warning codes. STARTUP/SHUTDOWN and equalize button
System Network	Conext Xanbus™ (publish-subscribe network, no need for hubs or special cards)
Emissions	FCC Part 15, Class B Industry Canada ICES-003 Issue 5, Class B
Regulatory approvals	CSA C22.2 No. 107.1-01 - General Use Power Supplies California tariff Rule 21-compliant and certified to UL1741SA
Enclosure Type	NEMA Type 1—Indoor
Rated Temperature Range (meets specifications)	32–77 °F (0–25 °C)
Operational Temperature Range	-13–158 °F (-25–70 °C)
Storage Temperature Range	-40–185 °F (-40–85 °C)
Inverter Dimensions (H × W × D)	23 × 16 × 9" (580 × 410 × 230 mm)
Shipping Dimensions (H × W × D)	28 × 22 ½ × 15 ½" (711 × 572 × 394 mm)
Inverter Weight	125 lb (57 kg)
Shipping Weight	132 lb (60 kg)

Figure 67 Conext XW Pro Block Diagram



## Accessories

Accessory	Part Number
Conext XW Pro Power Distribution Panel	865-1015-01
Conext XW Pro Power Distribution Panel (Without AC Breakers)	865-1014-01
Conext XW Pro Conduit Box	865-1025-01
Conext XW Pro PDP 120/240V 60A Breaker Kit	865-1215-01
Conext Gateway	865-0329
Conext Configuration Tool (required for Rule 21 settings)	865-1155-01
Conext SCP System Control Panel	865-1050-01
Conext AGS Automatic Generator Start	865-1060-01
Conext MPPT solar charge controller MPPT 60 150	865-1030-1
Conext MPPT solar charge controller MPPT 80 600	865-1032
Conext Battery Monitor	865-1080-01

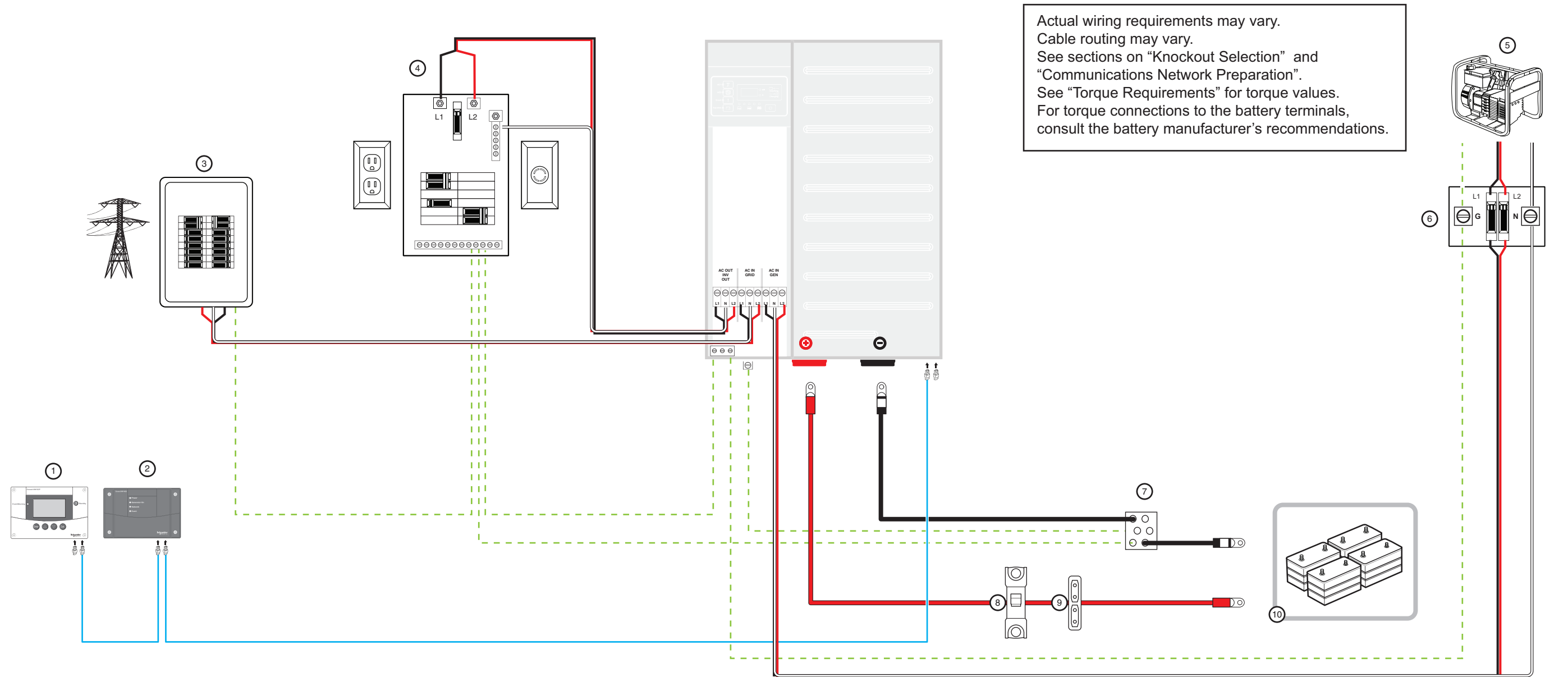


# Wiring Diagrams

*"Wiring Diagrams" above* illustrate the most basic configurations and are for reference only. Specific installations may require additional equipment to meet national or local electric codes. Ensure all safety requirements are strictly followed.

# Single-Inverter System (Backup Only) Without a Power Distribution Panel (PDP)

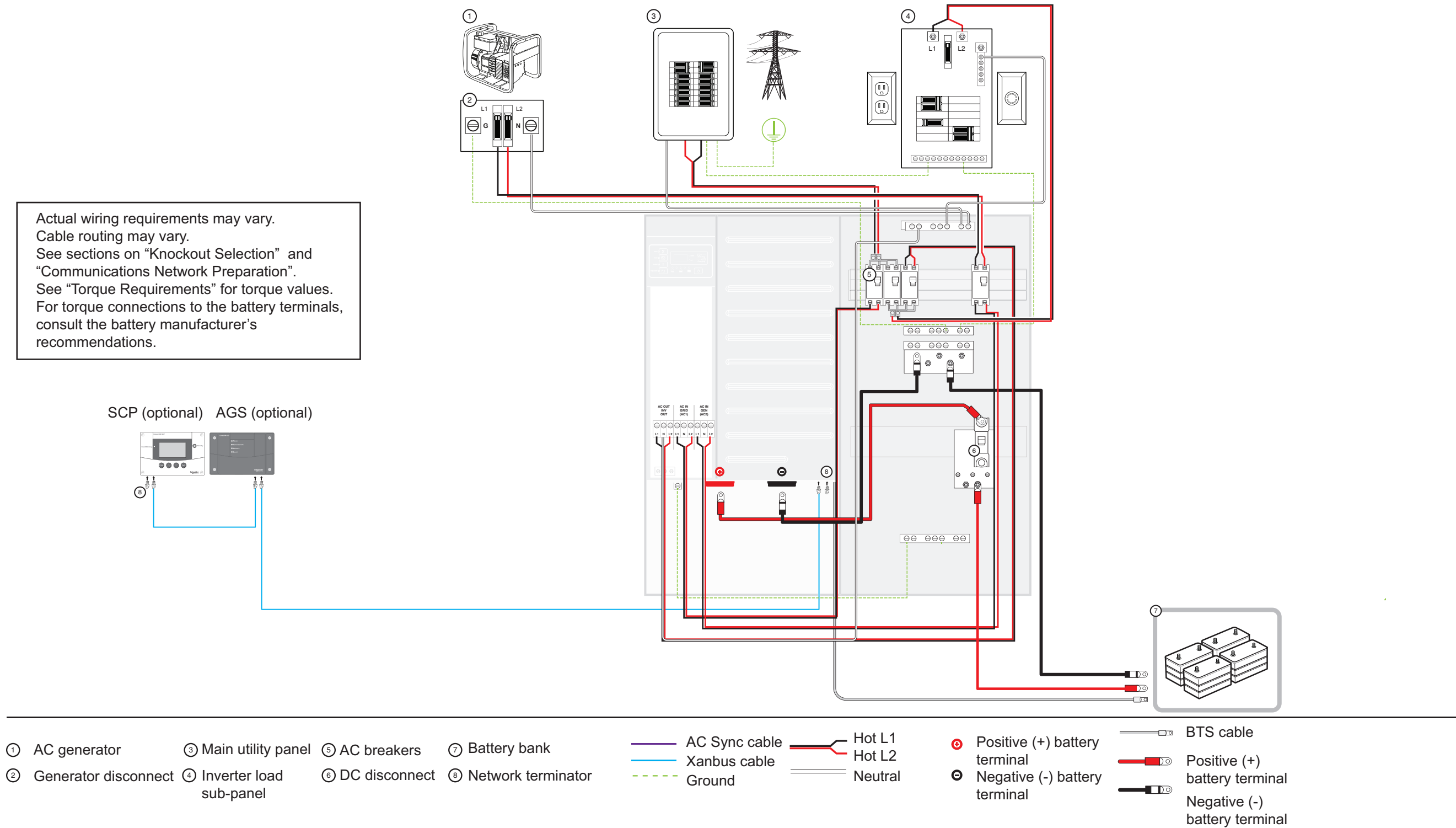
Figure 68 Single-Inverter System (Backup Only) Without a Power Distribution Panel (PDP)



- |                  |                           |                        |                                 |                         |                 |           |                                 |                                 |
|------------------|---------------------------|------------------------|---------------------------------|-------------------------|-----------------|-----------|---------------------------------|---------------------------------|
| ① SCP (optional) | ③ Main utility panel      | ⑤ AC generator         | ⑦ Negative ground bus           | ⑨ Fuse block (optional) | — AC Sync cable | — Hot L1  | ⊕ Positive (+) battery terminal | — Positive (+) battery terminal |
| ② AGS (optional) | ④ Inverter load sub-panel | ⑥ Generator disconnect | ⑧ Circuit breaker/DC disconnect | ⑩ Battery bank          | — Xanbus cable  | — Hot L2  | ⊖ Negative (-) battery terminal | — Negative (-) battery terminal |
|                  |                           |                        |                                 |                         | - - - Ground    | — Neutral |                                 |                                 |

# Single-Inverter System (Backup Only) With a Power Distribution Panel (PDP)

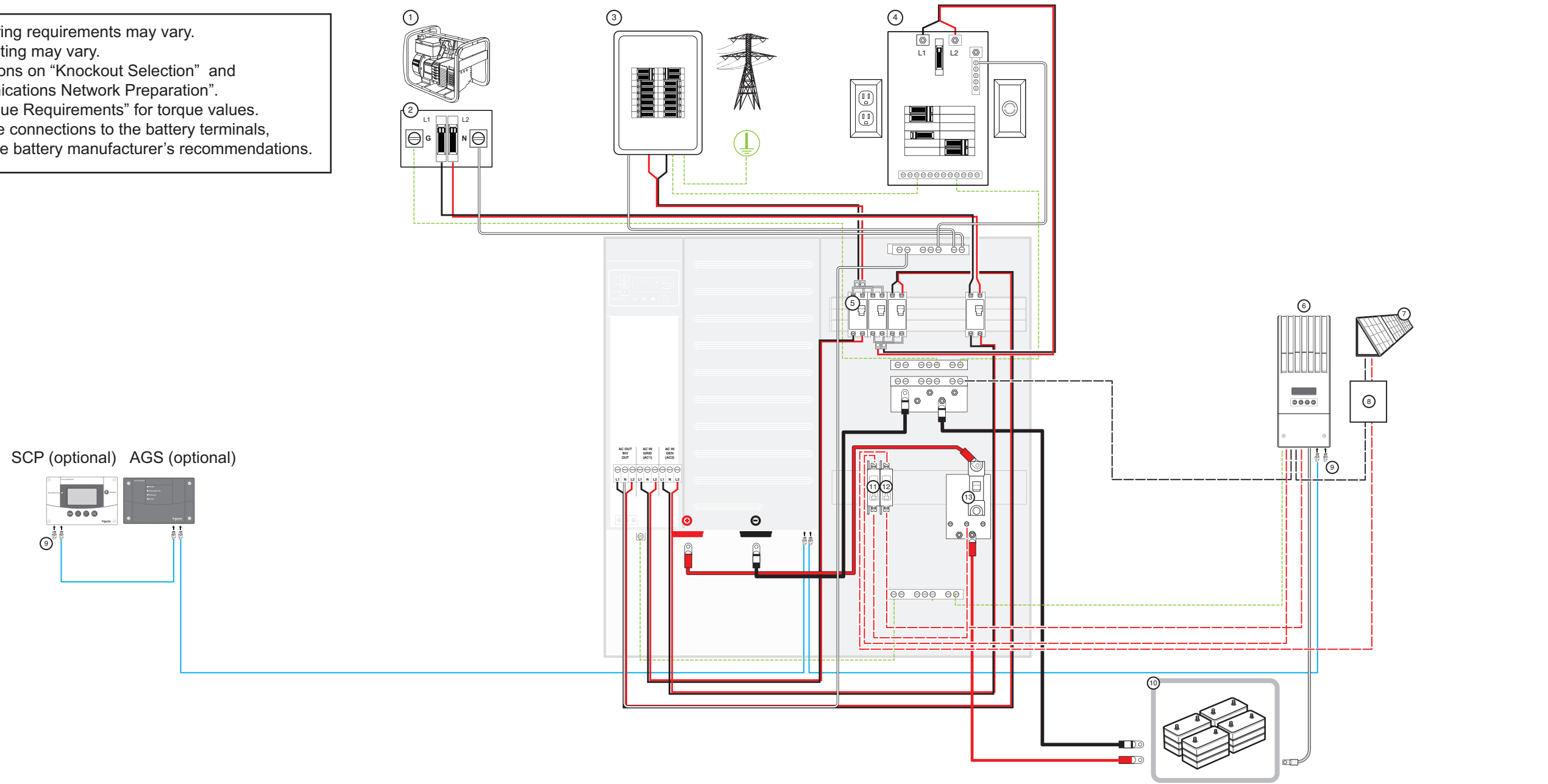
Figure 69 Single-Inverter System (Backup Only) With a Power Distribution Panel (PDP)



# Single-Inverter System Renewable Energy (Solar)

Figure 70 Single-Inverter System Renewable Energy (Solar)

Actual wiring requirements may vary.  
 Cable routing may vary.  
 See sections on "Knockout Selection" and  
 "Communications Network Preparation".  
 See "Torque Requirements" for torque values.  
 For torque connections to the battery terminals,  
 consult the battery manufacturer's recommendations.



- ① AC generator
- ② Generator disconnect
- ③ Main utility panel
- ④ Inverter load sub-panel
- ⑤ AC breakers
- ⑥ Conext MPPT 60 150 solar charge controller
- ⑦ PV array
- ⑧ DC combiner box
- ⑨ Network terminator
- ⑩ Battery bank
- ⑪ CC
- ⑫ PV

— AC Sync cable  
 — Xanbus cable

--- DC positive (+)  
 --- DC negative (-)  
 - - - Ground

— Hot L1  
 — Hot L2  
 — Neutral

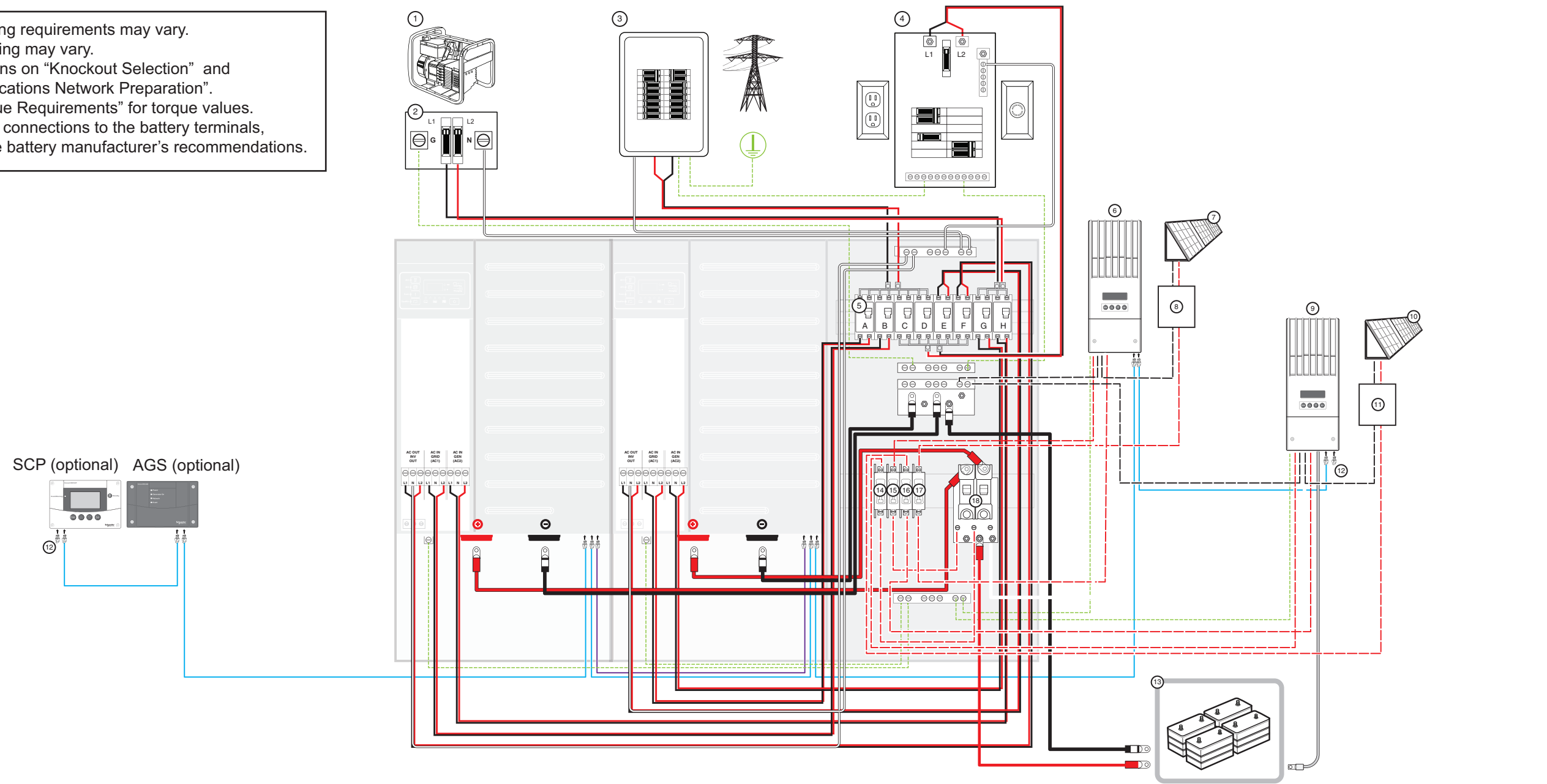
⊕ Positive (+) battery terminal  
 ⊖ Negative (-) battery terminal

— BTS cable  
 ⊕ Positive (+) battery terminal  
 ⊖ Negative (-) battery terminal

# Dual-Inverter System Renewable Energy (Solar)

Figure 71 Dual-Inverter System Renewable Energy (Solar)

Actual wiring requirements may vary.  
 Cable routing may vary.  
 See sections on "Knockout Selection" and  
 "Communications Network Preparation".  
 See "Torque Requirements" for torque values.  
 For torque connections to the battery terminals,  
 consult the battery manufacturer's recommendations.



- |                        |                                  |                                  |                      |                |                 |                   |                        |                     |         |                                 |                                 |
|------------------------|----------------------------------|----------------------------------|----------------------|----------------|-----------------|-------------------|------------------------|---------------------|---------|---------------------------------|---------------------------------|
| ① AC generator         | ④ Inverter load sub-panel        | ⑦ PV array 1                     | ⑩ PV array 2         | ⑬ Battery bank | ⑯ PV 2          | A. INV1 IN (Grid) | E. INV1 OUT (AC loads) | — AC Sync cable     | Hot L1  | ⊕ Positive (+) battery terminal | — BTS cable                     |
| ② Generator disconnect | ⑤ AC breakers                    | ⑧ DC combiner box 1              | ⑪ DC combiner box 2  | ⑭ CC 2         | ⑰ PV 1          | B. INV2 IN (Grid) | F. INV2 OUT (AC loads) | — Xanbus cable      | Hot L2  | ⊖ Negative (-) battery terminal | ⊕ Positive (+) battery terminal |
| ③ Main utility panel   | ⑥ MPPT solar charge controller 1 | ⑨ MPPT solar charge controller 1 | ⑫ Network terminator | ⑮ CC 1         | ⑱ DC disconnect | C. Grid bypass    | G. INV1 IN (Gen)       | --- DC positive (+) | Neutral |                                 | ⊖ Negative (-) battery terminal |
|                        |                                  |                                  |                      |                |                 | D. Grid bypass    | H. INV2 IN (Gen)       | --- DC negative (-) |         |                                 |                                 |
|                        |                                  |                                  |                      |                |                 |                   |                        | --- Ground          |         |                                 |                                 |

## **Schneider Electric**

As standards, specifications, and designs change from time to time, please ask for confirmation of the information given in this publication.

For other country details please contact your local Schneider Electric Sales Representative or visit the Schneider Electric Solar Business website at: <https://solar.schneider-electric.com>

© 2018 Schneider Electric. All Rights Reserved.