

## Morningstar TriStar MPPT 600V with Transfer Switch

### Grid-Tie PV with Battery Backup System Diagram for Grounded Inverters

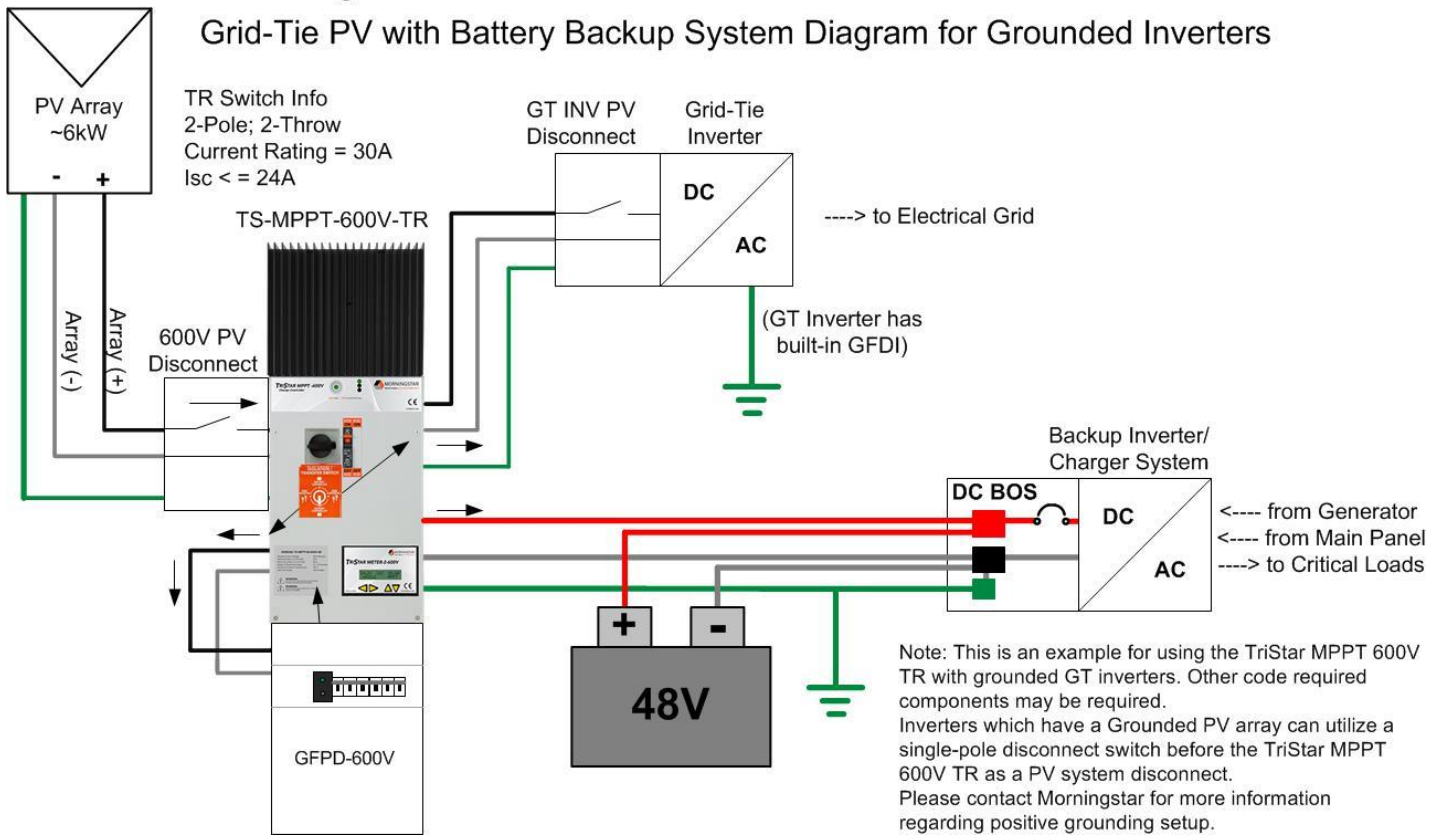

## Morningstar TriStar MPPT 600V with Transfer Switch

### Grid-Tie PV with Battery Backup System Diagram for Transformerless Inverters

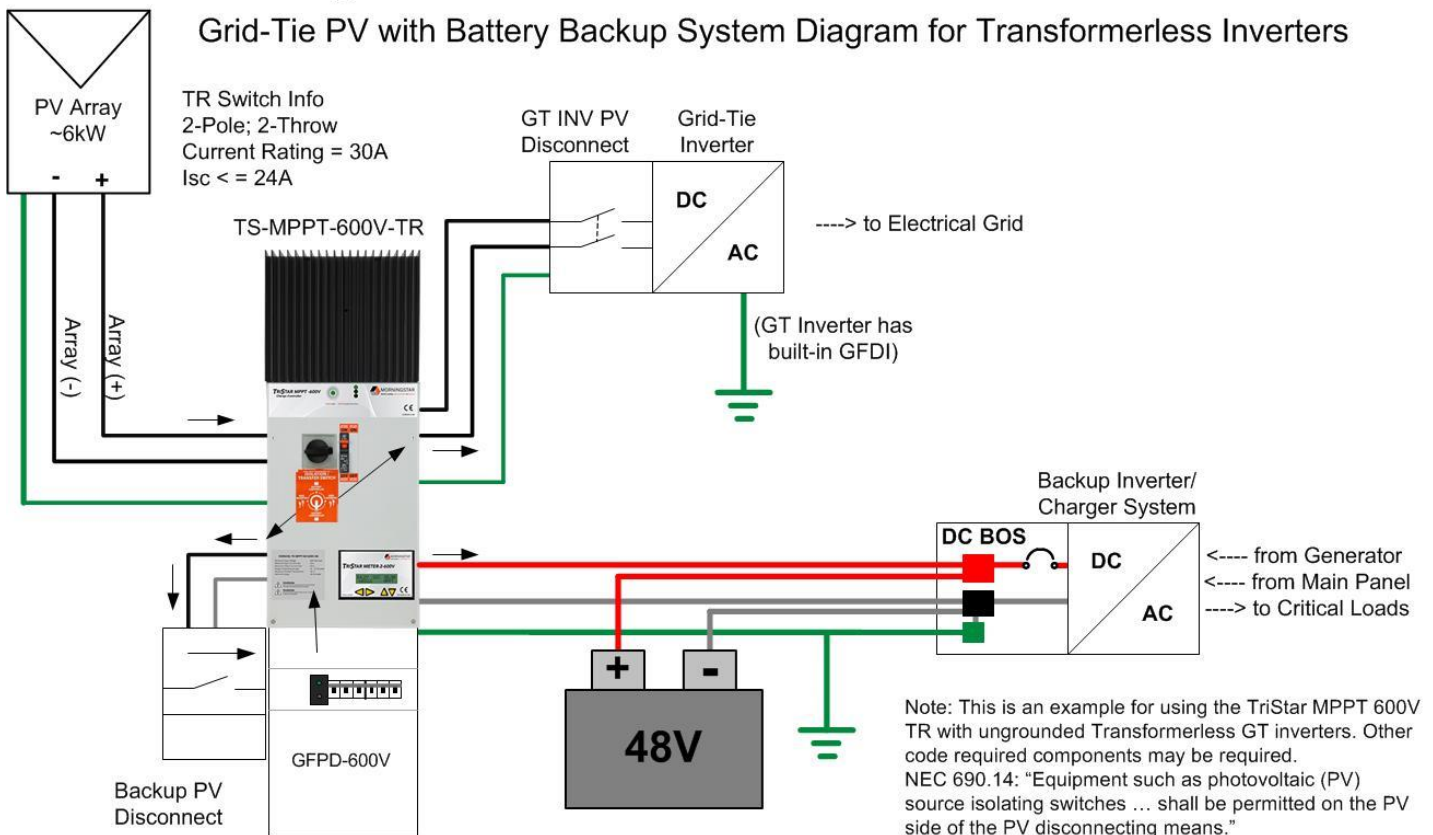

**Disclaimer:** These diagrams are a general overview and not intended to be a substitute for the installation and operation manual. Please read all of the instructions and cautions in the manual before beginning installation. Installation of this equipment should only be performed by qualified individuals.  
[http://www.morningstarcorp.com/wp-content/uploads/2015/05/Operation-Manual-TS-MPPT-600V-48-DB-TR\\_GFPD\\_v1.1.pdf](http://www.morningstarcorp.com/wp-content/uploads/2015/05/Operation-Manual-TS-MPPT-600V-48-DB-TR_GFPD_v1.1.pdf)